

BETTIS ACTUATOR & CONTROLS

SERVICE INSTRUCTIONS

DISASSEMBLY AND REASSEMBLY

FOR MODELS

RP500X, RP1100X, RPB500X & RPB1100X

SERIES PNEUMATIC ACTUATORS

PART NUMBER: 087993

REVISION: "C"

DATE: July 7, 1997

1.0 **INTRODUCTION**

- 1.1 This service procedure is a guide for general maintenance to be performed on RP500X, RP1100X, RPB500X and RPB1100X Double Acting and Spring Return series actuators.
- 1.2 When the model number has a "-S" as a suffix, then the actuator is special and may have some differences that are not included in this procedure.
- 1.3 Complete actuator refurbishment requires the actuator be dismantled from the valve or device it is operating.
- 1.4 Normal recommended service interval for this actuator series is five years to maximum total life cycle.

NOTE: Storage time is counted as part of the service interval.

1.5 DEFINITIONS

WARNING: If not observed, user incurs a high risk of severe damage to actuator and/or fatal injury to personnel.

CAUTION: If not observed, user may incur damage to actuator and/or injury to personnel.

NOTE: Advisory and information comments provided to assist maintenance personnel to carry out maintenance procedures.

- 1.6 **SAFETY** Products supplied by Bettis, in its "as shipped" condition, are intrinsically safe if the instructions contained within this Service Instruction are strictly adhered to and executed by well trained, equipped, prepared and competent personnel.

WARNING: For the protection of personnel working on Bettis actuators, this procedure should be reviewed and implemented for safe disassembly and reassembly. Close attention should be noted to the **WARNINGS, CAUTIONS and NOTES** contained in this procedure.

WARNING: This procedure should not supersede or replace any customers plant safety or work procedures. If a conflict arises between this procedure and the customers procedures the differences should be resolved in writing between an authorized customers representative and a authorized Bettis representative.

- 1.7 **TOOLS REQUIRED:** Set of Metric Allen Wrenches, small flat blade screw driver, medium size adjustable wrench and long nose or conventional pliers.

2.0 **GENERAL**

- 2.1 This procedure is applicable with the understanding that all electrical power and pneumatic pressure has been removed from the actuator. Also, it is understood that the actuator has been removed from the valve as well as all piping and accessories that are mounted on the actuator have been removed.

- 2.2 This procedure is written using the side of the housing with the inlet and outlet ports as a reference and this side will be considered the front of the actuator. The position indicator will be the top of the actuator.
- 2.3 When removing seals from seal grooves, use a small screwdriver with sharp corners rounded off or a commercial seal removing tool.
- 2.4 Use a non-hardening thread sealant on all pipe threads.

CAUTION: Apply the thread sealant per the manufacture's instructions.

- 2.5 Disassembly of actuator should be done in a clean area on a work bench.
- 2.6 Measure the exposed length of right and left stop screws and record each before loosening or removal.

3.0 **ACTUATOR DISASSEMBLY - END CAPS**

3.1 **END CAP REMOVAL DOUBLE ACTING ACTUATORS:** Remove the socket head cap screws from the end cap assemblies and remove the left and right end cap assemblies.

3.2 **END CAP REMOVAL SPRING RETURN ACTUATORS:**

CAUTION: RP/RPB spring return actuators contain a compressed spring cartridge. To avoid physical injury, exercise care in handling, disassembly and reassembly.

3.3 END CAP REMOVAL FOR RPB500X AND RPB1100X ONLY

WARNING: POSSIBLE RPB500X/1100X CARTRIDGE SPRING DEFECT. If the following instructions are not observed when disassembling subject actuator, user incurs a high risk of serious injury to personnel and/or severe damage to the actuator.

BEFORE disassembly of any RPB500X or RPB1100X Spring Return Actuator, read and understand all of the attached information. See the following notes to see if these special instructions apply to your actuator.

If your actuator is a model RP500X-SRX or RP1100X-SRX proceed directly to section 3.4.

NOTE: These special service instructions apply **only** to any Bettis Model RPB500X-SRX and RPB1100X-SRX Spring Return actuator **with** serial number references having as the first two digits in the serial number, 95 **or** 96, **or** the following specific serial numbers 01.96, 02.96, 03.96, 04.96, 05.96 06.96, 07.96, 08.96, 09.96, 10.96, 11.96, 12.96, 01.97, 02.97, 03.97 and 04.97 **AND** which **DO NOT** have a S/S tag attached to the end cap with the following part number - 123166.

*If your Bettis Model RPB500X-SRX and RPB1100X-SRX Spring Return actuator serial number is **different from the above list, or has the s/s tag 123166 previously installed,** you may, at your option, disregard these special instructions and **go to section 3.4***

NOTE: After reading all of the attached information, if you are not certain of how to follow these instructions or have any questions, **DO NOT PROCEED** with actuator disassembly. Call your local Bettis Valve Automation Center, Bettis UK LTD. (at phone number 44-1489-885333), or Bettis Corp. (at phone number 281-463-5100), or facsimile 281-463-5153, Attn.: Service Manager.

WARNING: Spring return actuator end caps contain a compressed spring cartridge. To avoid serious physical injury exercise care in handling, disassembly and reassembly. Use all of the parts contained within the service kit and referenced on drawing #123166 (Page 9). Do not proceed if items 3, 4, 5 and 6 are not in the service kit ("Tension Tools" drawing #123166) (Page 9). Contact Bettis UK LTD., Bettis Corp. or an authorized Bettis VAC representative to obtain any missing items.

NOTE: Refer to RPB500X/RPB1100X Spring Cartridge Assembly Service drawing part number 123166 (Page 8). If any prior section has not been completed, do so now before proceeding.

3.3.1 Visually inspect both right and left end caps for any signs of damage or physical abuse.

WARNING: If damaged or missing components are noted, DO NOT DISASSEMBLE the actuator any further. Exercise extreme care in handling of actuator and contact an authorized Bettis representative or Bettis.

3.3.2 Refer to drawing number; 123166 (Page 8); select the **left end cap**, carefully loosen, and unscrew one (1) only socket cap screw (item 1) and washer from the housing.

Replace the socket capscrew with one of the long hex head capscrews (hereafter referred to as - "Tension Tool") or L-shaped, "Tension Tool" and tension nut supplied in the service kit (see drawing 123166 (Page 9); items 3, 4, 5 and 6).

WARNING: Be certain to thread one tension nut (drawing 123166, Page 8, items 5 and 6) and re-using one previously removed washer, place one washer onto each of the "Tension Tools" **BEFORE** threading into housing. Do not substitute any of these items.

After securely screwing the "Tension Tool" (item 3 or 4) fully into the housing (**ensuring a minimum of eleven turns for proper thread engagement**), rotate the tension nut down the "Tension Tool" until the tension nut and washer are securely tightened against the end cap.

3.3.3 Locate the opposing socket capscrew (item 2) which is **180 degrees** from the installed "Tension Tool" and repeat procedure 3.3.2.

Check to ensure that both "Tension Tools" and tension nuts are securely tightened and that they are 180 degrees apart.

WARNING: If the above actions have not been successful do not proceed any further: Contact Bettis UK LTD., Bettis Corp. or an authorized Bettis representative.

3.3.4 Carefully loosen, and evenly unscrew (counter clockwise) the two remaining socket capscrews (drawing 123166, Page 8, items 1 and 2) until the end cap is secured only by the "Tension Tool" and tension nuts.

3.3.5 **SEE WARNING BELOW** - Alternately holding each of the "Tension Tools" (to prevent unscrewing) in position, carefully and evenly turn (counter clockwise) each of the tension nuts to allow the end cap to evenly move away from the housing until a full 1/2" (12.8 mm) gap is achieved between the end cap and the housing. STOP AT THIS POINT OF THE PROCEDURE FOR THE FIRST CHECKPOINT.

3.3.6 **CHECKPOINT ONE:** With the end cap at this position (1/2" away from housing) there should be no spring tension forcing the end cap away from the housing. IF TENSION IS PRESENT, DO NOT PROCEED WITH ANY FURTHER DISASSEMBLY. Reverse the procedure ensuring that all four original socket capscrews and the end cap are secure and replace all stop screws. Call Bettis UK LTD., Bettis Corp. or an authorized Bettis representative for further instructions. If no tension is present continue to 3.3.7.

WARNING: If the spring cartridge is not completely defective at this point and time, no spring tension will be felt on the tension nuts. Do not assume that all is satisfactory. Do not remove the "Tension Tools" (Items 3 and 4) at this time. Proceed only as per the following instructions.

3.3.7 If spring tension was not present at 3.3.6, continue to evenly back out the tension nuts (Items 5 and 6), until the hub (5-65) and the pin (5-50) can be clearly seen.

NOTE: In some actuators, the spring may be installed reverse (inverted) of that shown in view 2.3.8 of drawing 123166 (Page 8). In those instances, continue backing off the tension nuts until the connection point between the Spring Retaining Hub (5-65) and Spring Retainer Pin (5-50) can be clearly seen. Refer to drawing 123166 (Page 21). Details "A" and "B". DO NOT REMOVE THE "TENSION TOOLS" AT THIS TIME.

3.3.8 **CHECKPOINT TWO:** Carefully check the following two points:

- A) The hub (5-65) should be screwed fully against the pin's (5-50) shoulder, without any hub or pin threads visible.
- B) There should not be any visible gap between the hub and pin. DO NOT REMOVE THE "TENSION TOOLS" AT THIS TIME.

WARNING: **ONLY** if both conditions are correct, (A) + (B) may you proceed to **CHECKPOINT THREE**. If both points have not been met, or if you are unsure - DO NOT PROCEED WITH ANY FURTHER DISASSEMBLY. Reverse the procedure ensuring that all four original socket capscrews and the end cap are secure and replace all stop screws. Call Bettis UK LTD., Bettis Corp. or an authorized Bettis representative for further instructions.

3.3.9 **CHECKPOINT THREE:** Very carefully, use the "GO" and "NO GO" drawings (see drawing 123166, Detail "A") to decide if the Spring Retainer Pin (5-50) is properly flared = "GO" or not = "NO GO."

NOTE: The flare is intended to prevent the hub (5-65) from disengaging (unscrewing) from the pin (5-50). Expansion or "flaring cracks" are normal, and do not by themselves, constitute an improper flare. What you are looking for is a "FLARE" LARGE ENOUGH TO PREVENT the pin (5-50) from passing through (unscrewing or backing "off") the threads of the hub (5-65). Use drawing part number 123166 (Page 8) to decide which of the following conditions exist.

3.3.9.1 The spring cartridge is a "GO." This means that the spring cartridge has passed CHECKPOINTS ONE, TWO and THREE (spring cartridge is mechanically locked to prevent unintentional or sudden release of spring forces).

WARNING: ONLY if you are certain the conditions called for in 3.3.9.1 have been met, and you have double checked, should you proceed. If you are unsure, assume that you have a "NO GO" - DO NOT PROCEED WITH ANY FURTHER DISASSEMBLY. Reverse the procedure ensuring that all four original socket capscrews and the end cap are secure and replace all stop screws. Call Bettis UK LTD., Bettis Corp. or an authorized Bettis representative for further instructions.

3.3.9.2 If you are certain that the "left" spring cartridge is a "GO," remove the "Tension Tools" and tension nuts, and set the left end cap and spring cartridge aside.

WARNING: DO NOT ASSUME THAT BECAUSE THE LEFT SPRING CARTRIDGE PASSED THE THREE CHECKPOINTS THAT THE RIGHT SPRING CARTRIDGE WILL. CAREFULLY FOLLOW THE SAME SAFETY INSTRUCTIONS WITH THE SAME ATTENTION TO CARE AND DETAIL FOR THE RIGHT SIDE.

3.3.9.3 Use the same procedure beginning at 3.3.2 to decide if the "right" side is a "GO."

3.3.9.4 **If both sides are "GO"**, find in the service kit a small Stainless Steel tag stamped with the part number 123166. When reassembling, install this tag to any of the four, short, end cap screws on either end cap (by passing the socket capscrew through the hole in the tag) when reinstalling the end caps. This tag will identify actuators which have been inspected and passed "GO", preventing the need for these special procedures should the actuator need to be disassembled again. If **both** spring cartridges are "GO" then move forward to 3.5 and continue.

WARNING: After reading ALL of the information contained in section 3.3, if you are not certain of how to follow these instructions or have any questions, DO NOT PROCEED with actuator disassembly. Call BETTIS UK LTD. (phone 44-1489-885333), or facsimile (44-1489-885200), Bettis Corp. (phone 281-463-5100), or facsimile (281-463-5153, Attn.: Service Manager), or call your local Bettis Authorized Valve Automation Center or Representative.

3.4 SPRING RETURN ACTUATORS - END CAP REMOVAL

WARNING: The following instructions are only for Bettis RP and RPB 500X-SRX and 1100X-SRX spring return actuators which do not meet the special instruction needs or requirements of section 3.3.

3.4.1 Visually inspect the actuators SR End Caps for any sign of unusual damage or physical abuse.

CAUTION: If cracks or broken components are noticed, DO NOT DISASSEMBLE the actuator. Exercise care in handling and contact a Bettis Actuator & Controls authorized representative.

3.4.2 Loosen but do not remove the hex nut on the SR module stop screw.

3.4.3 Carefully loosen and evenly unscrew four socket cap screws from right end cap. Note that end cap moves away from housing as socket cap screws are unscrewed.

WARNING: The spring preload should have been released when right end cap has moved approximately 1/4" inch (6.4 mm) away from housing. Do not proceed further if the right end cap is still under spring load when right end cap (has moved 3/8" inches (9.5 mm) away from housing. Re-tighten socket cap screws and contact a Bettis representative.

CAUTION: For RP and RPB 500X-SRX and 1100X-SRX the spring(s) are contained in the form of a "spring cartridge" that is not mechanically connected to the end cap. Care must be taken to ensure that the "spring cartridge" does not fall out when handling the end caps and cause injury or physical damage.

3.4.4 Repeat procedure 3.4 for the left end cap taking care to follow instructions.

3.5 HOUSING DISASSEMBLY

3.5.1 Remove the socket head cap screw, the indicator and the cap from the top of the torque shaft.

3.5.2 Rotate the torque shaft until the pistons are flush with the housing. Mark the torque shaft and housing for ease of reassembly.

3.5.3 After marking torque shaft and housing, rotate the torque shaft until the pistons are disengaged. Pull on the piston ribs and remove the piston.

3.5.4 Remove the retaining ring from the bottom of the housing and remove the torque shaft out through the bottom of the housing. Using the front of the housing as a reference, record the location (position) of the right and left piston bearing.

4.0 GENERAL REASSEMBLY

4.1 Remove and discard all old seals, retaining rings and bearings.

4.2 All parts should be cleaned to remove all dirt and other foreign material prior to inspection.

4.3 Inspect the inside walls of the housing for wear and scoring, light wear or tracing, barely detectable to touch is acceptable. Inspect the piston and torque shaft teeth for excessive wear. Inspect the torque shaft and housing for excessive wear in the area that they contact each other.

4.4 All seals, bearings, retaining rings and a new thrust washer are contained in the GH-Bettis Service kit.

5.0 ACTUATOR REASSEMBLY

5.1 If removed earlier, install a retaining ring into the top retaining groove of the torque shaft. Install o-ring seals into the seal grooves on each end of the torque shaft. Install the torque shaft through the housing.

5.2 Install the thrust washer on the bottom end of the torque shaft and retain with a retaining ring.

5.3 Rotate the torque shaft until the marks that were added in step 3.9 line up.

5.4 Install a bearing and a o-ring onto both pistons.

5.5 **PISTON INSTALLATION:** For double acting and spring return actuators failing close (clockwise), assemble the piston per step 5.6. For spring return actuators failing open (counter clockwise) use step 5.7.

- 5.6 With the front (air port side) of the housing facing you install a piston into the left end of the housing. The piston should have the bearing against the back side of the housing cylinder. Install the remaining piston into the right end of the housing. This piston should have the bearing against the front side of the housing cylinder.
- 5.7 With the front (air port side) of the housing facing you, install a piston into the left end of the housing. The piston should have the bearing against the front side of the housing cylinder. Install the remaining piston into the right end of the housing. This piston should have the bearing against the back side of the housing cylinder.
- 5.8 With the torque shaft in the position indicated in step 5.3, push on the end of both pistons and engage the piston teeth with the torque shaft teeth. The pistons must enter the housing simultaneously.
- 5.9 END CAP INSTALLATION - DOUBLE ACTING ACTUATORS: Install the stop screws into the end caps. Install o-ring, washer and jam nut onto the stop screws.
- 5.9.1 Install a o-ring into the recess in the end cap where the air passage port hole in the housing mates with the end cap.
- 5.9.2 Install a o-ring onto the outer diameter of the end caps. Continue end cap installation at step 5.11.
- 5.10 END CAP INSTALLATION - SPRING RETURN ACTUATORS: Install the stop screw into the end cap until the stop screw just appears through the back side of the end cap enough to install the o-ring, washer and jam nut onto the stop screws.
- 5.10.1 Install a o-ring into the recess in the end cap where the air passage port hole in the housing mates with the end cap.
- 5.10.2 Install a o-ring onto the outer diameter of the end caps.
- 5.10.3 Push on the pistons until they have traveled as far into the housing as they will go.
- NOTE: The pistons must enter the housing simultaneously.
- 5.10.4 Install the spring cartridges (SR) into each end of the housing.
- NOTE: The end of the SR cartridge with the hole in it will face the end caps.
- 5.11 Install the end caps onto the actuator housing, retaining with socket head cap screws and using a flat washer on each screw.
- 5.12 Install the cap and indicator onto the torque shaft and retain with a socket head cap screw.
- 5.13 Adjust both stop screws back to settings recorded in section 2 step 2.6.

ECN	DATE	REV		BY*	DATE
Released	October, 1989	A	COMPILED	Bill Cornelius	July 7, 1997
13010	January, 1993	B	CHECKED	Bill Cornelius	July 7, 1997
15888	July, 1997	C	APPROVED	Tom Jeansonne	July 7, 1997

* Signatures on file Bettis Actuator & Controls, Waller, Texas

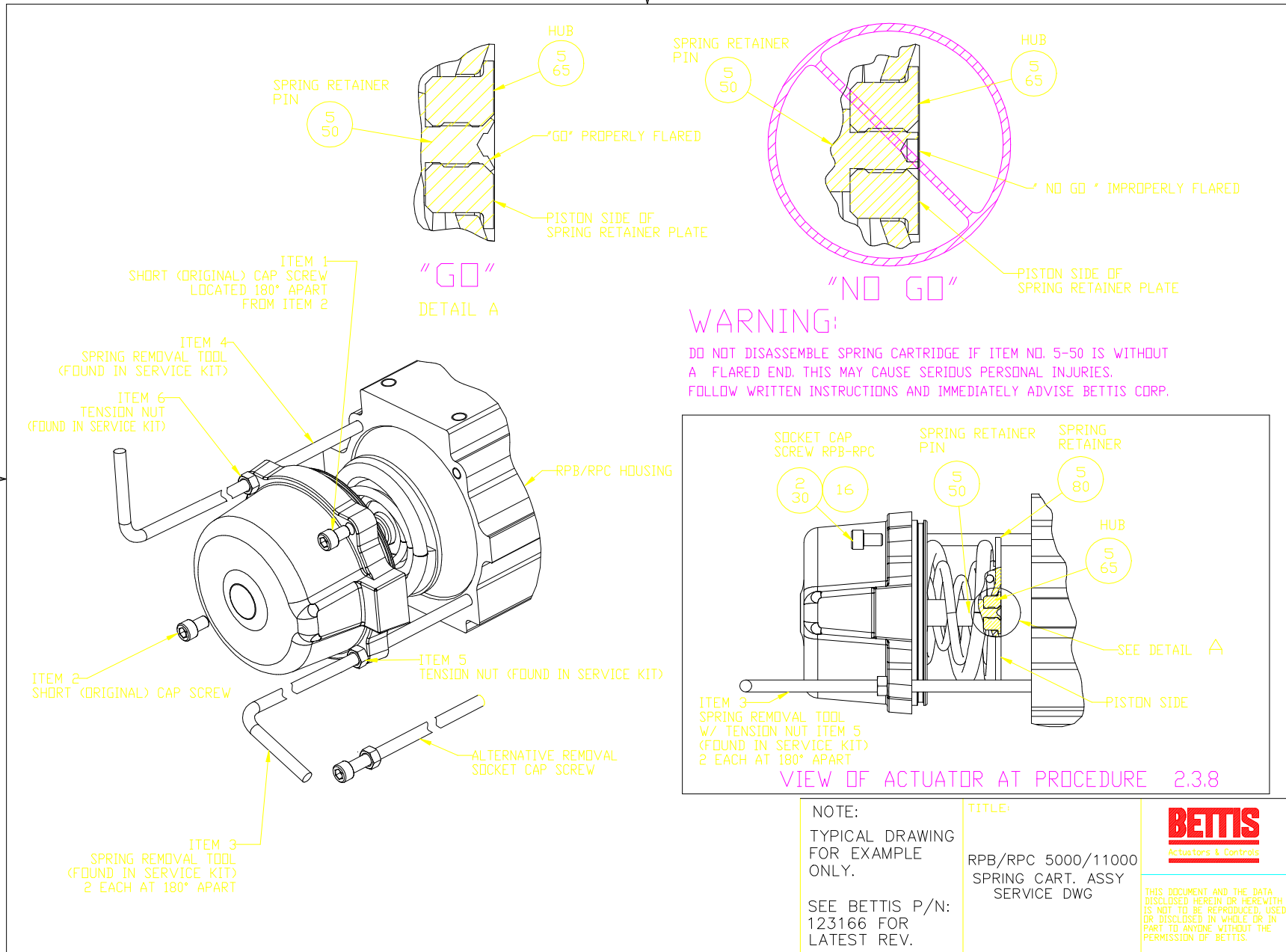

NOTE:
 TYPICAL DRAWING FOR EXAMPLE ONLY.
 SEE BETTIS P/N: 123166 FOR LATEST REV.

TITLE:
 RPB/RPC 5000/11000
 SPRING CART. ASSY
 SERVICE DWG

BETTIS
 Actuators & Controls

THIS DOCUMENT AND THE DATA DISCLOSED HEREIN OR HEREWITH IS NOT TO BE REPRODUCED, USED OR DISCLOSED IN WHOLE OR IN PART TO ANYONE WITHOUT THE PERMISSION OF BETTIS.