

**BETTIS ACTUATOR & CONTROLS**

**SERVICE INSTRUCTIONS**

**DISASSEMBLY AND REASSEMBLY**

**FOR MODELS**

**RPC25X THROUGH RPC1100X**

**DOUBLE ACTING AND**

**SPRING RETURN SERIES**

**PNEUMATIC ACTUATORS**

PART NUMBER: 123180

REVISION: "B"

DATE: JUNE 16, 1997

REPLACES: RPC Pneu P-2 Dated June 6, 1996

## CONTENTS

<b>SECTION 1 – INTRODUCTION</b>		<b>PAGE</b>
1.1	General	3
1.2	Definitions	3
1.3	Safety	3
1.4	Service Support Items	3
1.5	Bettis Reference Materials	4
1.6	General Information	4
1.7	Lubrication Requirements	4
<b>SECTION 2 – GENERAL ACTUATOR – DISASSEMBLY</b>		<b>4</b>
<b>SECTION 3 – ACTUATOR DISASSEMBLY</b>		<b>5</b>
3.1	Double Acting – Preparation	5
3.2	Double Acting – Stop Screw Removal	5
3.3	Double Acting – End Cap Removal	5
3.4	Double Acting – Housing Disassembly	5
<b>SECTION 4 – SPRING RETURN – DISASSEMBLY</b>		<b>6</b>
4.1	Spring Return – Preparation	6
4.2	Spring Return – Reassembly	7
4.3	Spring Return – End Cap/Spring Removal	7
4.4	<u>Spring Return – End Cap/Spring Removal</u> <u>Special Section – Certain RPC500X And RPC1100X</u> <u>All Actuators not required to use section 4.3</u>	10
4.5	Spring Return – Spring/Cartridge Conversion	10
4.6	Spring Return – Housing Disassembly	11
<b>SECTION 5 – ACTUATOR ASSEMBLY</b>		<b>11</b>
5.1	General Reassembly	11
5.2	Housing Reassembly – Double Acting/Spring Return	11
5.3	Double Acting Actuators - End Cap Reassembly	15
5.4	Spring Return Actuators - End Cap Reassembly	16
5.5	Cycle and Leak Test	17
5.6	Return to Service	17
<b>SECTION 6.0 – ACTUATOR SUPPORT INFORMATION</b>		
	RPC & RPB Spring Chart, 25X-SR Through 365X-SR	18
	RPC & RPB Spring Chart, 500X-SR Through 1100X-SR	19
	RPC Double Acting, Typical Assembly Drawing	20
	RPC Spring Return, Typical Assembly Drawing	21
	RPC500x and 1100X Spring Cartridge Service Drawing	22

## 1.0 INTRODUCTION

### 1.1 GENERAL

- 1.1.1 This service procedure is offered as a guide to enable general maintenance to be performed on Bettis RPC25X, RPC45X, RPC100X, RPC225X, RPC365X, RPC500X and RRC1100X Double Acting and Spring Return Series pneumatic actuators.
- 1.1.2 Complete actuator refurbishment requires the actuator be dismantled from the valve or device it is operating.
- 1.1.3 Normal recommended service interval for this actuator series is five years to maximum total life cycle.

**NOTE:** Storage time is counted as part of the service interval.

### 1.2 DEFINITIONS

**WARNING:** If not observed, user incurs a high risk of severe damage to actuator and/or fatal injury to personnel.

**CAUTION:** If not observed, user may incur damage to actuator and/or injury to personnel.

**NOTE:** Advisory and information comments, provided to assist maintenance personnel to carry out maintenance procedures.

- 1.3 **SAFETY** : Products supplied by Bettis, in its "as shipped" condition, are intrinsically safe if the instructions contained within these Service Instructions are strictly adhered to and executed by well trained, equipped, prepared and competent personnel.

**WARNING:** For the protection of personnel working on Bettis actuators, this procedure should be reviewed and implemented for safe disassembly and reassembly. Close attention should be noted to the **WARNINGS, CAUTIONS and NOTES** contained in this procedure.

**WARNING:** This procedure should not supersede or replace any customers plant safety or work procedures. If a conflict arises between this procedure and the customers procedures the differences should be resolved in writing between an authorized customers representative and an authorized Bettis representative.

### 1.4 SERVICE SUPPORT ITEMS

- 1.4.1 Bettis Service/Seal Kit or other needed parts.
- 1.4.2 Commercial leak testing solution.
- 1.4.3 Non-hardening thread sealant.
- 1.4.4 **TOOLS REQUIRED:** Set of Metric Allen Wrenches, snap ring pliers, flat blade screw driver and medium size adjustable wrench.

## 1.5 **BETTIS REFERENCE MATERIALS**

- 1.5.1 RPC25X-1100X Double Acting Series Assembly Drawing P/N 118158, Page 20.
- 1.5.2 RPC25X-1100X-SR Spring Return Series Assembly Drawing P/N 118159, Page 21.
- 1.5.3 RPC500X/RPC1100X Spring Cartridge Assembly Service Drawing P/N 123166, Page 22.

## 1.6 **GENERAL INFORMATION**

- 1.6.1 This procedure is applicable with the understanding that:
  - 1.6.1.1 All electrical power has been removed from the actuator.
  - 1.6.1.2 All pressure and pressure sources have been removed from the actuator.

**WARNING: It is possible, that the actuator may contain a dangerous gas (Sour gas/H<sub>2</sub>S, Oxygen, Nitrogen, etc.) or liquid (Chlorine, Condensates, etc.). Ensure that all proper measures have been taken to prevent dangerous exposure or release of these types of residues before commencing any work.**

- 1.6.1.3 Actuator has been removed from the valve or the device that the actuator is controlling.
  - 1.6.1.4 All piping and accessories that are connected to the actuator have been removed.
- 1.6.2 This procedure should only be implemented by a technically competent technician who should take care to observe good workmanship practices.
- 1.6.3 Numbers in parentheses, ( ) indicate the bubble number (reference number) used on the Bettis Assembly Drawing and Actuator Parts List.

## 1.7 **LUBRICATION REQUIREMENTS**

- 1.7.1 Lubricants, other than those listed in steps 1.7.1.1 and 1.7.1.2 should not be used without prior written approval of Bettis Product Engineering.
  - 1.7.1.1 Standard temperature service (40°F to +180°F, -40°C to +82°C) use Kronaplate 50 lubricant. Kronaplate 50, ESL-4 is contained in the standard Bettis Service Kit.
  - 1.7.1.2 High temperature service (0°F to +350°F, -18°C to +177°C) use Kronaplate 100 lubricant. Kronaplate 100 lubricant, ESL-5 lubricant is contained in the high temperature Bettis Service Kit.

## 2.0 **GENERAL ACTUATOR DISASSEMBLY**

**WARNING:** Ensure that all electrical and pressurized power sources are isolated and disconnected before commencing any work.

**NOTE:** Refer to assembly drawings 118158 (Page 20), 118159 (Page 21) and 123166 (Page 22). The following disassembly and reassembly instructions are provided for the RPC25X through RPC1100X series actuators, double acting and spring return models are included.

**WARNING:** Double acting and spring return instructions have been separated to avoid confusion and must not be interchanged.

**CAUTION:** If the model number is suffixed with the letter "S", the actuator is a "special" and may have some important differences to the standard actuator. This "special designation" may require special service instructions, consult with the factory before commencing any work.

### **3.0 RPC DOUBLE ACTING - DISASSEMBLY INSTRUCTIONS**

**WARNING:** This section is for double acting actuators only. Proceed to section 4.0 for spring return actuator instructions and see all WARNINGS, CAUTIONS AND NOTES.

#### **3.1 PREPARATION:**

Place the actuator on suitable clean working surface with the position indicator facing up and the inlet and outlet pressure ports facing the technician. When referring to "left" and "right" in these instructions, this is the actuator to technician relationship/position assumed.

#### **3.2 DOUBLE ACTING - STOP SCREW REMOVAL**

**WARNING:** Never attempt actuator disassembly or remove stop screws (1-60) while cam ring (1-40) is pressed against the stop screws by pneumatic forces. These forces must be removed before beginning disassembly. Ensure that the following two steps are completed before any further disassembly.

- 3.2.1 The setting and location of each stop screw (1-60) should be checked and recorded before the jam nuts (1-70) and stop screws (1-60) are loosened or removed.
- 3.2.2 Using a wrench, loosen both jam nuts (1-70) and completely remove the stop screws (1-60) from the housing (1-10). Remove and discard the o-ring seals (3-130) found on the stop screws.

#### **3.3 DOUBLE ACTING ACTUATORS - END CAP REMOVAL**

**WARNING:** This section is for double acting actuators only. Proceed to section 4.0 for spring return actuator instructions and see all WARNINGS, CAUTIONS AND NOTES.

**NOTE:** Refer to RPC double acting assembly drawing part number 118158 (Page 20).

- 3.3.1 Using an appropriate metric Allen wrench, remove four socket cap screws (2-30) complete with washers (2-40) from right end cap (2-20). Repeat for the left end cap (2-10)
- 3.3.2 Remove right end cap (2-20) from housing (1-10). Repeat for the left end cap (2-10)
- 3.3.3 Remove and discard two o-ring seals each (3-110) and (3-120) from right and left end caps.

#### **3.4 DOUBLE ACTING - HOUSING DISASSEMBLY**

**NOTE:** Refer to RPC double acting assembly drawing part number 118158 (Page 20).

- 3.4.1 Rotate torque shaft (1-20) until two pistons (1-50) can be removed from housing (1-10).

**NOTE:** It is recommended the piston and torque shaft orientations are observed and recorded/marked for ease of future reassembly.

3.4.2 Remove two pistons (1-50) from housing (1-10).

3.4.3 Remove and discard piston seal (3-100), heel bearing (3-80) and outer bearing (3-90) from both pistons (1-50).

3.4.4 Remove (unsnap) position indicator (4) from torque shaft (1-20) by lifting/prying with one or two screwdrivers.

**NOTE:** It is recommended the position indicator to torque shaft orientation is observed and recorded/marked for ease of future reassembly.

3.4.5 Using snap ring pliers, remove retaining ring (3-70) from torque shaft (1-20).

3.4.6 Remove thrust washer (3-60) and thrust bearing (3-50) from torque shaft (1-20).

3.4.7 Remove torque shaft (1-20) by passing through from the bottom of housing (1-10).

**NOTE:** It is recommended the cam to torque shaft orientations are observed and recorded/marked for ease of future reassembly

**CAUTION:** As the torque shaft is removed from the housing the stop screw cam (1-40) will disengage from the torque shaft, becoming loose. Ensure that the stop screw cam does not fall out and cause injury or damage.

3.4.8 Remove and discard o-ring seal (3-10), o-ring seal (3-20), lower bearing (3-40) and upper bearing (3-30) from torque shaft (1-20).

**WARNING:** Actuator disassembly is now complete. Review all procedures to ensure that all steps have been completed. Inspect all parts carefully, looking for any physical damage and excessive wear. Never re-use a part or assembly which appears damaged, worn or not suitable for continued service. If any doubt exist, replace the part.

## 4.0 SPRING RETURN - DISASSEMBLY INSTRUCTIONS

**WARNING:** POSSIBLE RPC500X/1100X SPRING CARTRIDGE DEFECT. If the following instructions are not observed when disassembling subject actuator, user incurs a high risk of serious injury to personnel and/or severe damage to the actuator.

**BEFORE** disassembly of any RPC Spring Return Actuator, read and understand all of the attached information.

4.1 **PREPARATION:** Place the actuator on suitable clean working surface with the position indicator facing up and the inlet and outlet ports facing the technician. When referring to "left" and "right" in these instructions this is the actuator to technician relationship/position assumed.

#### 4.2 SPRING RETURN - STOP SCREW REMOVAL

**WARNING:** Never attempt actuator disassembly or remove stop screws (1-60) while cam ring (1-40) is pressed against the stop screws by pneumatic forces. These forces must be removed before beginning disassembly. Ensure that the following two steps are completed before any further disassembly.

- 4.2.1 The setting and location of each stop screw (1-60) should be checked and recorded before the jam nuts (1-70) and stop screws (1-60) are loosened or removed.
- 4.2.2 Using a wrench, loosen both jam nuts (1-70) and completely remove the stop screws (1-60) from the housing (1-10). Remove and discard the o-ring seals (3-130) found on the stop screws.

#### 4.3 SPRING RETURN ACTUATORS - END CAP REMOVAL

**WARNING: POSSIBLE RPC500X/1100X CARTRIDGE SPRING DEFECT.** If the following instructions are not observed when disassembling subject actuator, user incurs a high risk of serious injury to personnel and/or severe damage to the actuator.

**BEFORE** disassembly of any RPC500X or RPC1100X Spring Return Actuator, read and understand all of the attached information. See the following notes to see if these special instructions apply to your actuator.

*If your actuator is a model RPC25X-SRX, RPC45X-SRX, RPC100X-SRX, RPC225X-SRX OR RPC 365X-SRX proceed directly to section 4.4.*

**NOTE:** These special service instructions apply only to any Bettis Model RPC500X-SRX and RPC1100X-SRX Spring Return actuator with serial Number references as follows: 01.96, 02.96, 03.96, 04.96, 05.96, 06.96, 07.96, 08.96, 09.96, 10.96, 11.96, 12.96, 01.97, 02.97, 03.97 and 04.97 **AND** which **DO NOT** have a S/S tag attached to the end cap with the following part number - 123166. See also a similar WARNING for all RPB500X-SRX and RPB1100X-SRX that have as the first two digits in the serial number, 95 or 96.

*If your Bettis Model RPC500X-SRX and RPC1100X-SRX Spring Return actuator serial number is different from the above list, or has the s/s tag previously installed, you may, at your option, disregard these special instructions and go to section 4.4*

**NOTE:** After reading all of the attached information, if you are not certain of how to follow these instructions or have any questions, **DO NOT PROCEED** with actuator disassembly. Call your local Bettis Valve Automation Center, Bettis UK LTD. (at phone number 44-1489-885333), or Bettis Corp. (at phone number 281-463-5100), or facsimile 281-463-5153, Attn.: Service Manager.

**WARNING:** Spring return actuator end caps contain a compressed spring cartridge. To avoid serious physical injury exercise care in handling, disassembly and reassembly. Use all of the parts contained within the service kit and referenced on drawing #123166 (Page 22). Do not proceed if items 3, 4, 5 and 6 are not in the service kit ("Tension Tools" drawing #123166) (Page 22). Contact Bettis UK LTD., Bettis Corp. or an authorized Bettis VAC representative to obtain any missing items.

**NOTE:** Refer to RPC-SR assembly drawing part number 118159 (Page 21). and RPC500X/RPC1100X Spring Cartridge Assembly Service drawing part number 123166 (Page 22). If section 4.2 has not been completed, do so now before proceeding.

- 4.3.1 Visually inspect both right and left end caps (2-20 and 2-10) for any signs of damage or physical abuse.

**WARNING: If damaged or missing components are noted, DO NOT DISASSEMBLE the actuator any further. Exercise extreme care in handling of actuator and contact an authorized Bettis representative or Bettis.**

- 4.3.2 Refer to drawing number; 118159 (Page 21) and 123166 (Page 22). ; select the **left end cap**, carefully loosen, and unscrew one (1) only socket cap screw (2-30) and washer (2-40) from the housing.

Replace the socket capscrews with one of the long hex head capscrews (hereafter referred to as - "Tension Tool") or L-shaped, "Tension Tool" and tension nut supplied in the service kit (see drawing 123166 (Page 22); items 3, 4, 5 and 6).

**WARNING: Be certain to thread one tension nut (drawing 123166 (Page 22), items 5 and 6) and re-use one washer (2-40) onto each of the "Tension Tools" BEFORE threading into housing. Do not substitute any of these items.**

After securely screwing the "Tension Tool" (item 3 or 4) fully into the housing (**ensuring a minimum of eleven turns for proper thread engagement**), rotate the tension nut down the "Tension Tool" until the tension nut and washer are securely tightened against the end cap.

- 4.3.3 Locate the opposing socket capscrews (2-30) which is **180 degrees** from the installed "Tension Tool" and repeat procedure 4.3.2.

Check to ensure that both "Tension Tools" and tension nuts are securely tightened and that they are 180 degrees apart.

**WARNING: If the above actions have not been successful do not proceed any further: Contact Bettis UK LTD., Bettis Corp. or an authorized Bettis representative.**

- 4.3.4 Carefully loosen, and evenly unscrew (counter clockwise) the two remaining socket capscrews (drawing 123166 (Page 22), items 1 and 2) until the end cap (2-20) is secured only by the "Tension Tool " and tension nuts.

- 4.3.5 **SEE WARNING BELOW** - Alternately holding each of the "Tension Tools" (to prevent unscrewing) in position, carefully and evenly turn (counter clockwise) each of the tension nuts to allow the end cap to evenly move away from the housing until a full 1/2" (12.8 mm) gap is achieved between the end cap and the housing (1-10). STOP AT THIS POINT OF THE PROCEDURE FOR THE FIRST CHECKPOINT.

- 4.3.6 **CHECKPOINT ONE:** With the end cap at this position (1/2" away from housing) there should be no spring tension forcing the end cap away from the housing. IF TENSION IS PRESENT, DO NOT PROCEED WITH ANY FURTHER DISASSEMBLY. Reverse the procedure ensuring that all four original socket capscrews and the end cap are secure and replace all stop screws. Call Bettis UK LTD., Bettis Corp. or an authorized Bettis representative for further instructions. If no tension is present continue to 4.3.6.

**WARNING: If the spring cartridge is not completely defective at this point and time, no spring tension will be felt on the tension nuts. Do not assume that all is satisfactory. Do not remove the "Tension Tools" (Items 3 and 4) at this time. Proceed only as per the following instructions.**

4.3.7 If spring tension was not present at 4.3.6, continue to evenly back out the tension nuts (Items 5 and 6), until the hub (5-65) and the pin (5-50) can be clearly seen.

**NOTE:** In some actuators, the spring may be installed reverse (inverted) of that shown in view 2.3.8 of drawing 123166 (Page 22). In those instances, continue backing off the tension nuts until the connection point between the Spring Retaining Hub (5-65) and Spring Retainer Pin (5-50) can be clearly seen. Refer to drawing 123166 (Page 22). Details "A" and "B". DO NOT REMOVE THE "TENSION TOOLS" AT THIS TIME.

4.3.8 **CHECKPOINT TWO:** Carefully check the following two points:

- A) The hub (5-65) should be screwed fully against the pin's (5-50) shoulder, without any hub or pin threads visible.
- B) There should not be any visible gap between the hub and pin. DO NOT REMOVE THE "TENSION TOOLS" AT THIS TIME.

**WARNING: ONLY if both conditions are correct, (A) + (B) may you proceed to CHECKPOINT THREE. If both points have not been met, or if you are unsure - DO NOT PROCEED WITH ANY FURTHER DISASSEMBLY. Reverse the procedure ensuring that all four original socket capscrews and the end cap are secure and replace all stop screws. Call Bettis UK LTD., Bettis Corp. or an authorized Bettis representative for further instructions.**

4.3.9 **CHECKPOINT THREE:** Very carefully, use the "GO" and "NO GO" drawings (see drawing 123166, Detail "A") to decide if the Spring Retainer Pin (5-50) is properly flared = "GO" or not = "NO GO."

**NOTE:** The flare is intended to prevent the hub (5-65) from disengaging (unscrewing) from the pin (5-50). Expansion or "flaring cracks" are normal, and do not by themselves, constitute an improper flare. What you are looking for is a "FLARE" LARGE ENOUGH TO PREVENT the pin (5-50) from passing through (unscrewing or backing "off") the threads of the hub (5-65). Use drawing part number 123166 (Page 22) to decide which of the following conditions exist.

4.3.9.1 The spring cartridge is a "GO." This means that the spring cartridge has passed CHECKPOINTS ONE, TWO and THREE (spring cartridge is mechanically locked to prevent unintentional or sudden release of spring forces).

**WARNING: ONLY if you are certain the conditions called for in 4.3.9.1 have been met, and you have double checked, should you proceed. If you are unsure, assume that you have a "NO GO" - DO NOT PROCEED WITH ANY FURTHER DISASSEMBLY. Reverse the procedure ensuring that all four original socket capscrews and the end cap are secure and replace all stop screws. Call Bettis UK LTD., Bettis Corp. or an authorized Bettis representative for further instructions.**

4.3.9.2 If you are certain that the "left" spring cartridge is a "GO," remove the "Tension Tools" and tension nuts, and set the left end cap and spring cartridge aside.

**WARNING: DO NOT ASSUME THAT BECAUSE THE LEFT SPRING CARTRIDGE PASSED THE THREE CHECKPOINTS THAT THE RIGHT SPRING CARTRIDGE WILL. CAREFULLY FOLLOW THE SAME SAFETY INSTRUCTIONS WITH THE SAME ATTENTION TO CARE AND DETAIL FOR THE RIGHT SIDE.**

4.3.9.3 Use the same procedure beginning at 4.3.2 to decide if the "right" side is a "GO."

4.3.9.4 **If both sides are "GO"**, find in the service kit a small Stainless Steel tag stamped with the part number 123166. When reassembling, install this tag to any of the four, short, end cap screws on either end cap (by passing the socket capscrews through the hole in the tag) when reinstalling the end caps. This tag will identify actuators which have been inspected and passed "GO", preventing the need for these special procedures should the actuator need to be disassembled again. If **both** spring cartridges are "GO" then move forward to 4.5 and continue.

**WARNING:** After reading ALL of the information contained in section 4.0, if you are not certain of how to follow these instructions or have any questions, **DO NOT PROCEED** with actuator disassembly. Call BETTIS UK LTD. (phone 44-1489-885333), or facsimile (44-1489-885200), Bettis Corp. (phone 281-463-5100), or facsimile (281-463-5153, Attn.: Service Manager), or call your local Bettis Authorized Valve Automation Center or Representative.

#### 4.4 SPRING RETURN ACTUATORS - END CAP REMOVAL

**WARNING:** The following instructions are only for Bettis RPC25X-SRX, RPC45X-SRX, RPC100X-SRX, RPC225X-SRX AND RPC365X-SRX spring return actuators (See Page 21). Additionally, they may be used for RPC500X-SRX and RPC1100X-SRX spring return actuators which do not meet the special instruction needs or requirements of section 4.3.

4.4.1 Carefully loosen and evenly unscrew four socket cap screws (2-30) from right end cap (2-20). Note that end cap (2-10) moves away from housing (1-10) as socket cap screws (2-30) are unscrewed.

**WARNING:** The spring preload will have been released when right end cap (2-20) has moved approximately 1/4" inch (6.4 mm) away from housing (1-10). Do not proceed further if the right end cap is still under spring load when right end cap (2-20) has moved 3/8" inches (9.5 mm) away from housing (1-10). Retighten socket cap screws (2-30) and contact a Bettis representative.

**CAUTION:** For RPC25X-SRX through RPC365X-SRX the spring assembly is attached to the end caps and does not normally require disassembly from the end cap. For RPC500X-SRX and RPC1100X-SRX the spring(s) are contained in the form of a "spring cartridge" that is not mechanically connected to the end cap. Care must be taken to ensure that the "spring cartridge" does not fall out when handling the RPC500X-SRX and RPC1100X-SRX end caps and cause injury or physical damage.

4.4.2 Repeat procedure 4.4 for the left end cap (2-10) taking care to follow instructions.

#### 4.5 SPRING RETURN ACTUATORS - SPRING/SPRING CARTRIDGE REMOVAL OR CONVERSION.

**Note:** Refer to drawing number 118159 (Page 21) and Spring Identification Chart (Pages 18 & 19). RPC actuators are designed with two basic types of spring sets, **Socket capscrews Design** and **Spring Cartridge Design**, further identified below.

**4.5.1 SOCKET CAPSCREW DESIGN** - Found on RPC25X-SRX, RPC45X-SRX, RPC100X-SRX, RPC225X-SRX AND RPC365X-SRX (See Page 21). This design uses a socket capscrews (2-50) to contain and preload the spring(s). This design is readily identified by the acorn nut (2-150) on the outside of the end caps (2-10 and 2-20)

4.5.1.1 To disassemble this type of spring design remove the acorn nut (2-120), washer (2-130) and O-ring seal (3-140) discarding the O-ring. Repeat this procedure for both end cap assemblies.

4.5.1.2 Using a metric Allen wrench unscrew (counter clockwise) socket capscrews (2-50) until fully disengaged. Repeat this procedure for both end cap assemblies.

**4.5.2 SPRING CARTRIDGE DESIGN** - Found on RPC500X-SRX and RPC1100X-SRX. This design uses a FACTORY ASSEMBLED SPRING CARTRIDGE and will be free (loose) of the end cap upon end cap removal (See Pages 21 & 22). This design is readily identified by the LACK OF an acorn nut (2-150) on the outside of the end caps (2-10 and 2-20). To change spring ranges, the entire "cartridge" is changed out. Do not attempt disassembly, see warning below.

**WARNING: THE SPRING CARTRIDGE DESIGN (Section 4.5.2 & Pages 18, 21 & 22) IS PRELOADED AND MUST NOT BE DISASSEMBLED. Care must be taken to ensure that the "spring cartridge" does not fall out when handling the end cap and cause injury or physical damage.**

#### **4.6 SPRING RETURN - HOUSING DISASSEMBLY**

4.6.1 Once the spring return end caps are removed, further disassembly is the same as for double acting. Refer to 3.4 above and follow instructions.

## **5.0 ACTUATOR REASSEMBLY**

### **5.1 GENERAL REASSEMBLY**

**CAUTION:** Only new Bettis supplied seals that are still within the seals expectant shelf life, should be installed into the actuator being refurbished. Only the proper grease and parts, supplied by Bettis in applicable service kits, should be used in Bettis actuators.

5.1.1 Carefully remove and discard all seals, thrust washers, retainer rings and bearings.

5.1.2 All parts should be cleaned to remove all dirt and other foreign material prior to inspection.

5.1.3 Examine all seal grooves and sealing surfaces for wear and/or damage. Attention should be directed to threads, sealing surfaces and areas that will be subjected to sliding or rotating motion.

**CAUTION:** Actuator parts that reflect any of the above listed characteristics should be repaired or replaced with new parts.

### **5.2 HOUSING REASSEMBLY - GENERAL**

5.2.1 Position housing (1-10) on a suitable clean working surface with the smaller torque shaft bore uppermost with pressure ports and stop adjustment screws facing the technician.

**NOTE:** Lubricate all moving parts, seals and bearings using lubricant as identified in section 1.6, as installed.

5.2.2 Lubricate and install upper bearing (3-30) and lower bearing (3-40) onto torque shaft (1-20).

**NOTE:** Thermoplastic bearing may crack if opened further than necessary during installation. Only open the bearing enough to install.

5.2.3 Lubricate and install upper o-ring seal (3-10) and lower o-ring seal (3-20) onto torque shaft (1-20).

**WARNING: Ensure that retainer ring (1-30) is on torque shaft (1-20). If not re-install at this time.**

5.2.4 Partially install torque shaft (1-20) through the large hole in the bottom of housing (1-10) ensuring that the small (squared) end of the torque shaft enters first. See drawings under section 5.2.15, Detail "A" and "B".

5.2.5 Install the stop screw cam (1-40) over torque shaft (1-20) as it is partially into housing (1-10). Note that most cams have the word "TOP" embossed on them as an aid to reassembly. See drawings under section 5.2.15, Detail "A" and "B".

**NOTE:** The RPC stop screw cam has three basic center hole patterns. One is a splined pattern and has an odd gear tooth to prevent misalignment/orientation. The cam or torque shaft, having the same odd tooth, must be rotated until engagement is possible - do not force. This design is prevalent in RPC25X-SR through RPC365X-SRX. If the cam was recorded/marked at disassembly use these references as a quick guide to re-install. See drawings under section 5.2.15, Detail "A" and "B".

The second and third center hole patterns are - basically square and obround, and will accept the torque shaft in two different quadrants. Ensure that the cam is installed to allow for proper stop screw action/adjustment. If cam was recorded/marked at disassembly use these references as a quick guide to re-install. See drawings under section 5.2.15, Detail "A" and "B".

5.2.9 Complete installation of torque shaft (1-20) up through the small hole located in the top of housing (1-10). Take care not to disturb the o-rings and bearings.

5.2.10 Lubricate and install thrust bearing (3-50) onto torque shaft (1-20).

5.2.11 Lubricate and install thrust washer (3-60) onto torque shaft (1-20).

5.2.12 Install retainer ring (3-70) onto torque shaft (1-20).

5.2.13 Rotate torque shaft (1-20) so that the NAMUR drive slot (small slot found in top of torque shaft) is at 45 degrees to the bore of housing (1-10). See drawings under section 5.2.15, Detail "A" and note the position of stop screw cam.

5.2.14 Lubricate and install piston seal (3-100), outer bearing (3-90) and a heel bearing (3-80) to each piston (1-50).

5.2.15 Lubricate the inside diameter of housing and piston gear teeth. Insert two pistons (1-50) into housing (1-10) heel first, as indicated under 5.2.15.1, 5.2.15.2 or 5.2.15.3 .

**NOTE:** When the pistons enter the housing, they must enter evenly (synchronized). If one piston enters early (engages the torque shaft gearing before the other) it will prevent proper rotation of the actuator. See drawings under section 5.2.15, Details "A" and "B", next page. **See also 5.2.16 and the accompanying note and warning to check if installed correctly.**

- 5.2.15.1 **For a spring return (fail clockwise) actuator**, insert the heel of the right-hand piston (1-50) in front of torque shaft (1-20) and the heel of the left-hand piston (1-50) behind torque shaft (1-20) when viewed from above. When the pistons enter the housing, they must enter evenly (synchronized).

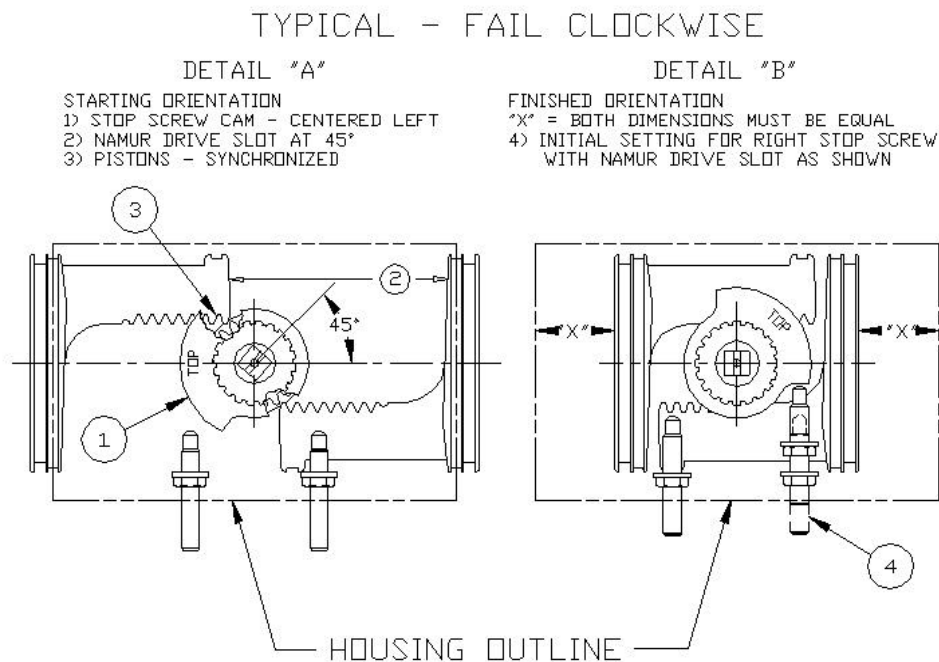

- 5.2.15.2 **For a spring return (fail counter clockwise) actuator**, insert the heel of the left-hand piston (1-50) in front of torque shaft (1-20) and the heel of the right-hand piston (1-50) behind torque shaft (1-20) when viewed from above. When the pistons enter the housing, they must enter evenly (synchronized).

TYPICAL - FAIL COUNTER CLOCKWISE

DETAIL "A"

- STARTING ORIENTATION  
1) STOP SCREW CAM - CENTERED RIGHT  
2) NAMUR DRIVE SLOT AT 45°  
3) PISTONS - SYNCHRONIZED

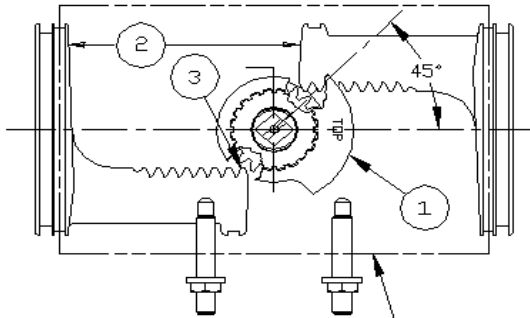

DETAIL "B"

- FINISHED ORIENTATION  
"x" = BOTH DIMENSIONS MUST BE EQUAL  
4) INITIAL SETTING FOR LEFT STOP SCREW  
WITH NAMUR DRIVE SLOT AS SHOWN

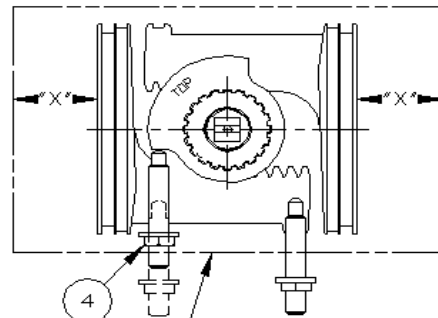

HOUSING OUTLINE

5.2.15.3 **Double acting actuators** are normally assembled with the heel of the right-hand piston (1-50) in front of torque shaft (1-20) and the heel of the left-hand piston (1-50) behind torque shaft (1-20) when viewed from above. When the pistons enter the housing, they must enter evenly (synchronized). If your double acting actuator was assembled opposite of this arrangement then reassemble as it was originally. Some special, control valving requires this "reverse" assembly.

TYPICAL - DOUBLE ACTING

DETAIL "A"

- STARTING ORIENTATION  
1) STOP SCREW CAM - CENTERED LEFT  
2) NAMUR DRIVE SLOT AT 45°  
3) PISTONS - SYNCHRONIZED

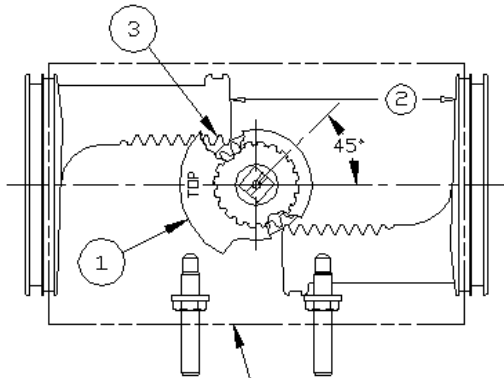

DETAIL "B"

- FINISHED ORIENTATION  
"x" = BOTH DIMENSIONS MUST BE EQUAL  
4) INITIAL SETTING FOR RIGHT STOP SCREW  
WITH NAMUR DRIVE SLOT AS SHOWN

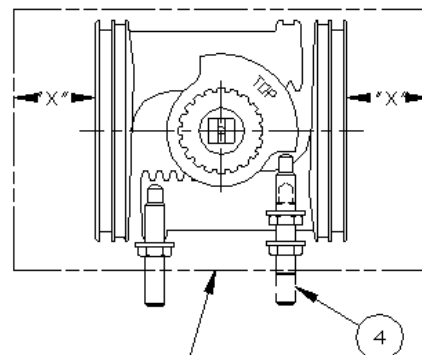

HOUSING OUTLINE

5.2.16 Continue to hand press the two pistons (1-50) into housing (1-10) causing rotation of the torque shaft (1-20) in a clockwise direction for a (fail clockwise) actuator or in a counter clockwise direction for a (fail counter clockwise) actuator. Continue until both piston heads (1-50) are as close to torque shaft (1-20) as possible. See drawings under section 5.2.15, Detail "B".

**NOTE:** Check the piston installation by measuring the distance from the outboard end of the two pistons (1-50) to the open end of the housing (1-10). The pistons (1-50) are correctly located when the two dimensions are equal and both pistons have been fully inserted into the housing. If these dimensions are not equal, remove the pistons and re-insert evenly. Check to ensure that all of the piston bearings have remained in place during piston installation.

**WARNING:** If procedure 5.2.15 through 5.2.16 and the notes accompanying them, are not performed correctly, the actuator may not fully rotate (90 degrees) in one or more directions. Additionally, if installed incorrectly, this would prevent the safe installation of spring sets and may prevent the full closing or opening of most valves.

5.2.17 Install jam nuts (1-70) onto stop screws (1-60).

5.2.18 Install o-ring seals (3-130) onto stop screws (1-60).

5.2.19 Lubricate and install stop screws (1-60) with jam nuts (1-70) and o-ring seals (3-130) into housing (1-10).

5.2.20 Install position indicator (4) into position on torque shaft (1-20). Ensure that the indicator matches the NAMUR drive slot, or the flow or working element of the valve, unless specified otherwise.

### 5.3 DOUBLE ACTING ACTUATOR - END CAP REASSEMBLY

NOTE: Refer to RPC assembly drawing part number 118158 (Page 20).

5.3.1 Lubricate and install o-ring seals (3-110) and (3-120) into left end cap (2-10) and right end cap (2-20).

**NOTE:** The small o-ring (3-120) is sometimes forgotten or misplaced. Ensure that it remains in place during assembly.

5.3.2 Install left end cap (2-10) to housing (1-10).

**NOTE:** Right and left end caps are not interchangeable. If the end cap profile does not match that of the housing, try the other end cap.

5.3.3 Install eight washers (2-40) onto eight socket cap screws (2-30).

5.3.4 Install four socket cap screws (2-30) complete with washers (2-40) through left end cap (2-10) and tighten into housing (1-10).

5.3.5 Install right end cap (2-20) to housing (1-10) in the same manner as the left end cap.

#### 5.4 **SPRING RETURN ACTUATORS - END CAP REASSEMBLY**

**NOTE:** Refer to RPC-SR assembly drawing part number 118159 ( Page 21).

5.4.1 Lubricate and install oring seals (3-110) and (3-120) into left end cap (2-10) and right end cap (2-20).

**NOTE:** The small oring (3-120) is sometimes forgotten or misplaced. Ensure that it remains in place during assembly.

#### 5.4.2 **END CAP INSTALLATION FOR SPRING RETURN ACTUATORS**

**NOTE:** The following procedures are best undertaken with the housing (1-10) resting on end (vertical position). Notice that this section is divided into two major actuator groups, 5.4.2.1 and 5.4.2.2.

##### 5.4.2.1 **RPC500X-SRX and RPC1100X-SRX:**

5.4.2.1.1 Place one spring cartridge assembly (5) in position against the left piston (1-50). The preferred method is to have the hub (5-65) end of the spring cartridge facing the piston. See assembly drawing 118159 (Page 21). (upper center view ) - RPC500X - 1100X spring cartridge assembly.

5.4.2.1.2 Install left end cap (2-10) to housing (1-10) ensuring that the pneumatic housing ports and left end cap ports are correctly aligned.

**NOTE:** Right and left end caps are not interchangeable. If the end cap profile does not match that of the body, try the other end cap.

5.4.2.1.3 Install four socket cap screws (2-30) complete with washers (2-40) through left end cap and screw into housing (1-10).

**NOTE:** If this actuator or any service kit used was equipped with a Stainless Steel tag stamped with part number 123166 and the spring cartridges have been checked and given a "GO" (SEE SECTION 4.3) install the tag under one of the socket cap screws (2-30).

5.4.2.1.4 Evenly tighten two diagonally opposite socket cap screws (2-30), then tighten the other two socket cap screws (2-30).

5.4.2.1.5 Repeat this procedure for the right end cap and spring cartridge.

##### 5.4.2.2 **RPC25X-SR through RPC365X-SR: END CAP INSTALLATION**

5.4.2.2.1 Install left end cap (2-10) ensuring that the pneumatic housing ports and left end cap ports are correctly aligned (Page 20).

**NOTE:** On this type of RPC-SR actuator the spring assembly is attached to the left end cap (2-10). If the springs are not present, install now as shown below.

**NOTE:** Right and left end caps are not interchangeable. If the end cap profile does not match that of the body, try the other end cap.

5.4.2.2.2 Install four socket cap screws (2-30) complete with washers (2-40) through left end cap and screw into housing (1-10).

5.4.2.2.3 Evenly tighten two diagonally opposite socket cap screws (2-30) evenly, then tighten the other two socket cap screws (2-30).

5.4.2.2.4 Repeat this procedure section for the right end cap and spring assembly.

## 5.5 **CYCLE AND LEAK TEST (Minimum)**

**CAUTION: All RPC actuators have exposed moving parts when operating. Ensure that no clothing, hair, shop rags, tools or other material becomes entangled.**

5.5.1 Cycle the actuator five (5) times, looking for smoothness of operation, mechanical problems, any parts that may be loose or missing and ensure that the actuator is traveling a minimum of 90 degrees in both directions.

**CAUTION: Never apply more than 125 p.s.i.g (8 BAR) to any RPC actuator during cycle testing.**

5.5.2 Apply a clean, dry power source such as instrument air and check for leaks using a commercial leak detectant liquid. Ensure that the actuator is tested in both directions of travel.

## 5.6 **RETURNING TO SERVICE (Minimum)**

5.6.1 Before mounting the actuator to the valve or driven device ensure that both are in the same position. For example: 1) Both actuator and valve are open or closed. OR 2) Both actuator and driven device are fully clockwise or counterclockwise.

5.6.2 Reset actuator stop screws (1-60) on completion of securing the actuator to the device it is to control.

5.6.3 Replace any tubing or pipe-work and/or accessories removed prior to disassembly

5.6.4 Retest the entire assembly for proper operation.

BETTIS RPC & RPB SPRING IDENTIFICATION CHART. 500X-SR THROUGH 1100X-SR							
COLUMNS			BAR/PSIG (NOMINAL OPERATING PRESSURE)				
			2.76/40	4.14/60	5.52/80	6.90/100	8.28/120
1	2	3	SPRING SET NUMBER				
MODEL & SPRING COLOR CODE	SPRING	NO. & COLOR OF STRIPES	(2)	(3)	(4)	(5)	(6)
			REQUIRED SPRING(S) FOR THE ABOVE SPRING SET NUMBER				
250 OR 251 YELLOW	A	1, YELLOW			XXXXXX		XXXXXX
	B	2, YELLOW	XXXXXX			XXXXXX	XXXXXX
	C	3, YELLOW		XXXXXX	XXXXXX	XXXXXX	XXXXXX
450 OR 451 BLACK	A	1, BLACK			XXXXXX		XXXXXX
	B	2, BLACK	XXXXXX			XXXXXX	XXXXXX
	C	3, BLACK		XXXXXX	XXXXXX	XXXXXX	XXXXXX
1000 OR 1001 GREEN	A	1, GREEN			XXXXXX		XXXXXX
	B	2, GREEN	XXXXXX			XXXXXX	XXXXXX
	C	3, GREEN		XXXXXX	XXXXXX	XXXXXX	XXXXXX
2250 OR 2251 BLUE	A	1, BLUE			XXXXXX		XXXXXX
	B	2, BLUE	XXXXXX			XXXXXX	XXXXXX
	C	3, BLUE		XXXXXX	XXXXXX	XXXXXX	XXXXXX
3650 OR 3651 ORANGE	A	1, ORANGE			XXXXXX		XXXXXX
	B	2, ORANGE	XXXXXX			XXXXXX	XXXXXX
	C	3, ORANGE		XXXXXX	XXXXXX	XXXXXX	XXXXXX

**HOW TO USE THIS CHART- (SEE ALSO SPRING ASSEMBLY DRAWING BELOW)**

**COLUMN 1** – Lists actuator model numbers and color of the stripes painted on the spring

**COLUMN 2** – Lists the three possible spring sizes a given actuator may have.

**COLUMN 3** - Lists the number and color of the paint stripes found on a particular spring.

**BAR/PSIG AND SPRING SET COLUMNS** – First line shows **BAR & PSIG** nominal operating pressures for spring sets (I.E., SR4) listed one row down.

**REQUIRED SPRING SECTION** – Shows **XXXXXX** when a particular spring is need to make a given spring set.

**EXAMPLE:** RPC250-SR4; Needs one "A" size (inner) spring which has one yellow stripe and one "C" size (Outer/Large) spring which has three yellow stripes.

**EXAMPLE:** RPC2250-SR5; Needs one "B" size (intermediate) spring which has two blue stripes and one "C" size (Outer/Large) spring which has three blue stripes.

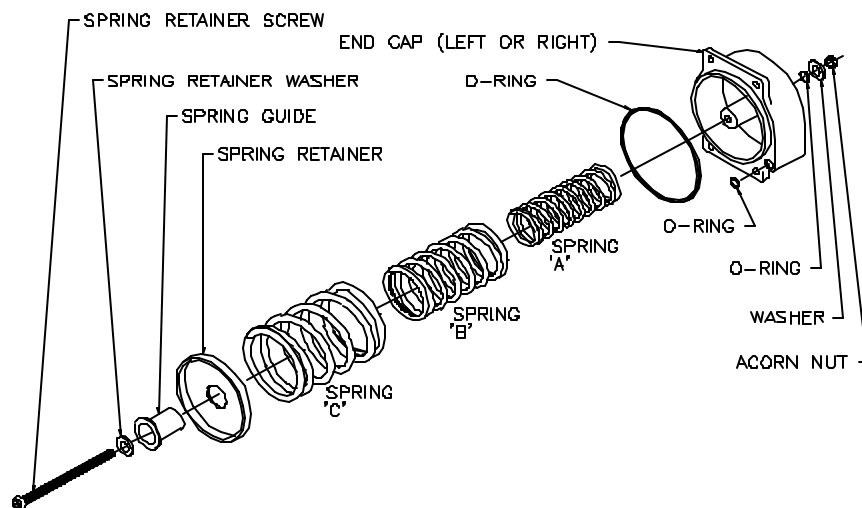

SPRING CARTRIDGE ASSEMBLY (LEFT OR RIGHT)

BETTIS RPC & RPB SPRING IDENTIFICATION CHART, 500X-SR THROUGH 1100X-SR							
COLUMNS			BAR/PSIG (NOMINAL OPERATING PRESSURE)				
1	2	3	2.76/40	4.14/60	5.52/80	6.90/100	8.28/120
MODEL & SPRING COLOR CODE	SPRING	NO & COLOR OF STRIPES	(2)	(3)	(4)	(5)	(6)
			REQUIRED SPRING(S) FOR THE ABOVE SPRING SET NUMBER				
5000 OR 5001 WHITE	A	1, WHITE			XXXXXX		XXXXXX
	B	2, WHITE	XXXXXX			XXXXXX	XXXXXX
	C	3, WHITE		XXXXXX	XXXXXX	XXXXXX	XXXXXX
11000 OR 11001 RED	A	1, RED			XXXXXX		XXXXXX
	B	2, RED	XXXXXX			XXXXXX	XXXXXX
	C	3, RED		XXXXXX	XXXXXX	XXXXXX	XXXXXX

Note: See "How To Use This Chart" instructions found on the prior page.

**NOTE: THE SPRING CARTRIDGE DESIGN** Found on RPC500X-SRX and RPC1100X-SRX uses a FACTORY ASSEMBLED SPRING CARTRIDGE. To change spring ranges, the entire "cartridge" is changed out. Do not attempt disassembly, see warning below.

**WARNING: THE SPRING CARTRIDGE DESIGN** (referred to above, in sections 4.3, 4.5.2 and the following drawing) IS PRELOADED AND MUST NOT BE DISASSEMBLED. Care must be taken to ensure that the "spring cartridge" does not fall out when handling the end cap and cause injury or physical damage.

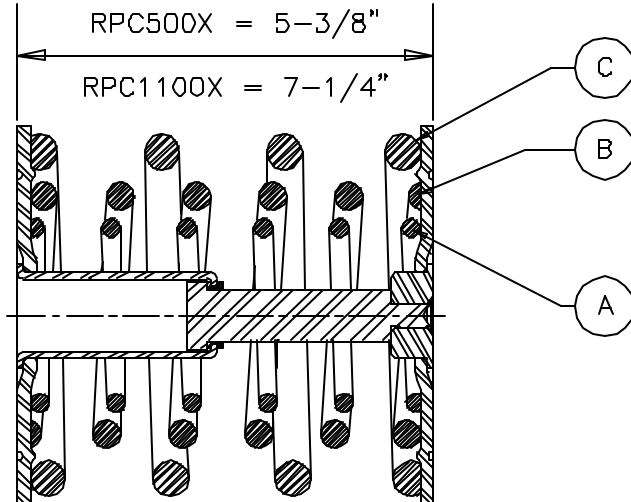

RPC500X-1100X  
SPRING CARTRIDGE ASSEMBLE  
DO NOT ATTEMPT TO DISASSEMBLE

ECN	DATE	REV	BY*	DATE
Released	June 16, 1997	B	Bill Cornelius	June 17, 1997
			Bill Cornelius	June 17, 1997
			Tom Jeansonne	June 17, 1997

\* Signatures on file Bettis Actuator & Controls, Waller, Texas

Three drawings follow (pages 20, 21 and 22).

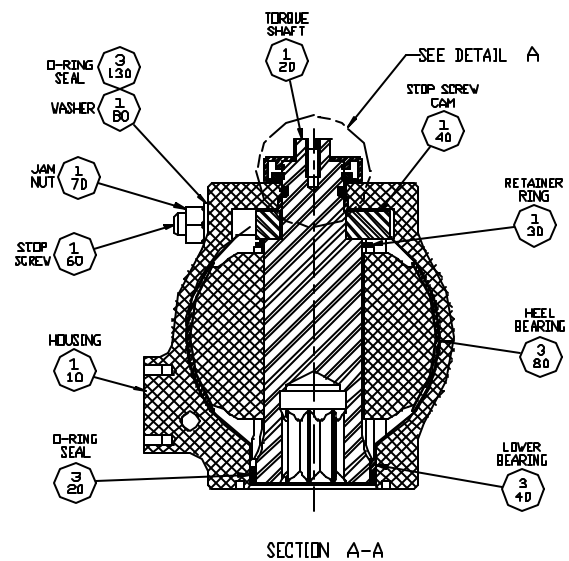
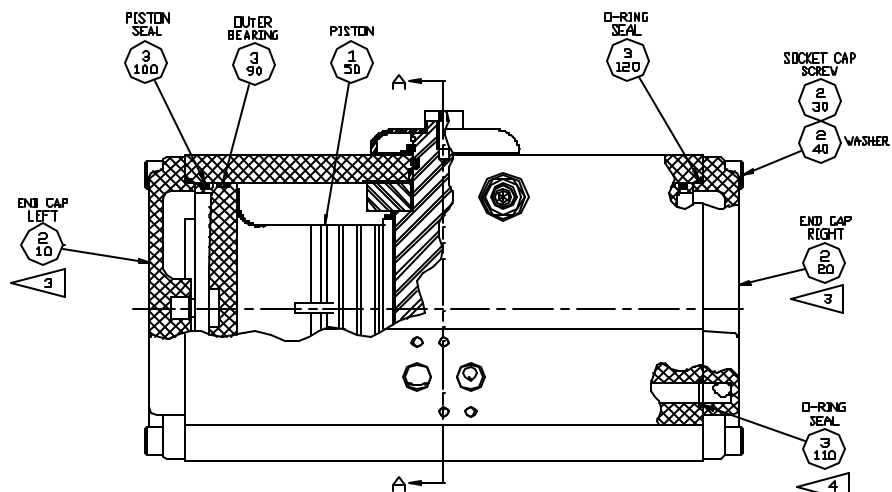
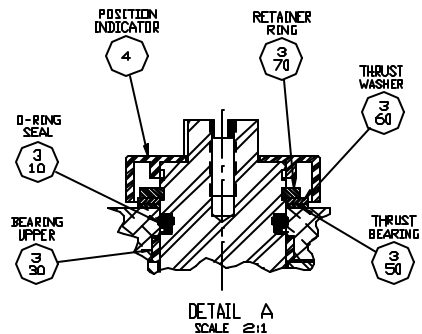

NOTES:

1. HOUSING AND COMPONENT CONFIGURATION CHANGES PER MODEL SIZE, OTHERWISE ALL ITEMS REMAIN THE SAME.
2. APPLY LUBRICANT (500) TO ALL MOVING PARTS.
3. RPC 500X AND 1100X MODELS DO NOT REQUIRE LEFT AND RIGHT END CAPS.
4. ITEM 2-10 IS UTILIZED FOR BOTH END CAPS.
5. ITEM 3-110 IS LOCATED ON THE END CAPS OF THE RPC-500X AND 1100X MODELS.

NOTE:  
 TYPICAL DRAWING  
 FOR EXAMPLE  
 ONLY.  
 SEE BETTIS P/N,  
 118108 FOR  
 LATEST REVISION

TITLE:  
 TYPICAL  
 ASSEMBLY DRAWING  
 RPC25X-1100X  
 DOUBLE ACTING



8 | 7 | 6 | 5 | 4 | 3 | 2 | 1

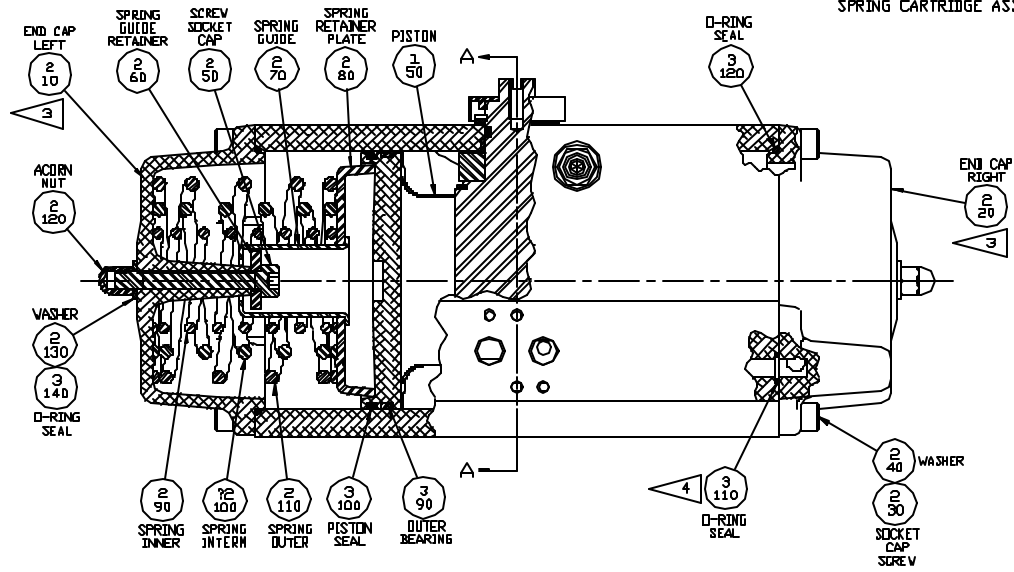
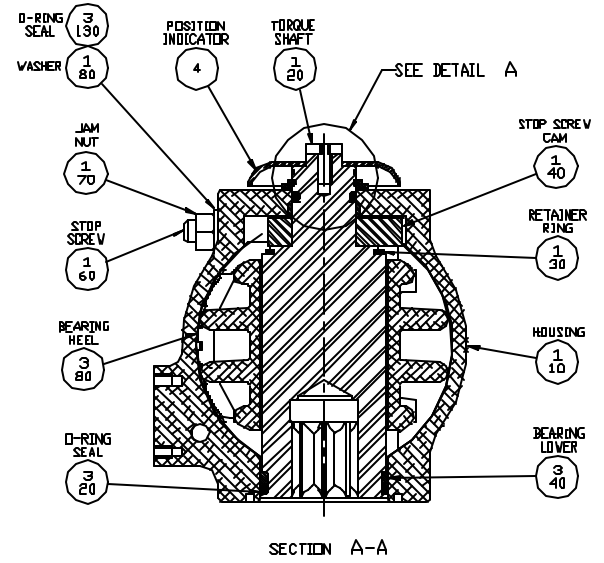
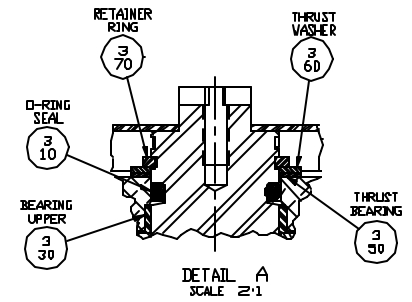
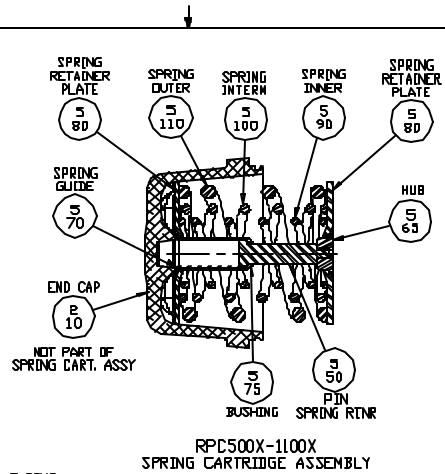

NOTES:

1. HOUSING AND COMPONENT CONFIGURATION CHANGES PER MODEL SIZE, OTHERWISE ALL ITEMS REMAIN THE SAME.

2. APPLY LUBRICANT (500) TO ALL MOVING PARTS.

3. RPC 365X, 500X AND 1100X MODELS DO NOT REQUIRE LEFT AND RIGHT END CAPS.

ITEM 2-10 IS UTILIZED FOR BOTH END CAPS.

4. ITEM 3-110 IS LOCATED ON THE END CAPS OF THE RPC-500X AND 1100X MODELS.

<p>NOTE:                  TYPICAL DRAWING                  FOR EXAMPLE                  ONLY.</p>	<p>TITLE                  TYPICAL                  ASSEMBLY DRAWING                  RPC25X-1100X                  SPRING RETURN</p>	
<p>SEE BETTIS P/N                  118189 FOR                  LATEST REVISION</p>	<p>THIS DOCUMENT AND THE DATA                  HEREIN ARE THE PROPERTY OF                  BETTIS. IT IS TO BE KEPT                  SECRET AND NOT TO BE                  REPRODUCED OR TRANSMITTED                  IN ANY FORM OR BY ANY                  MEANS, ELECTRONIC OR                  MECHANICAL, INCLUDING                  PHOTOCOPYING, RECORDING,                  OR BY ANY INFORMATION                  STORAGE AND RETRIEVAL                  SYSTEM.</p>	

8 7 6 5 4 3 2 1

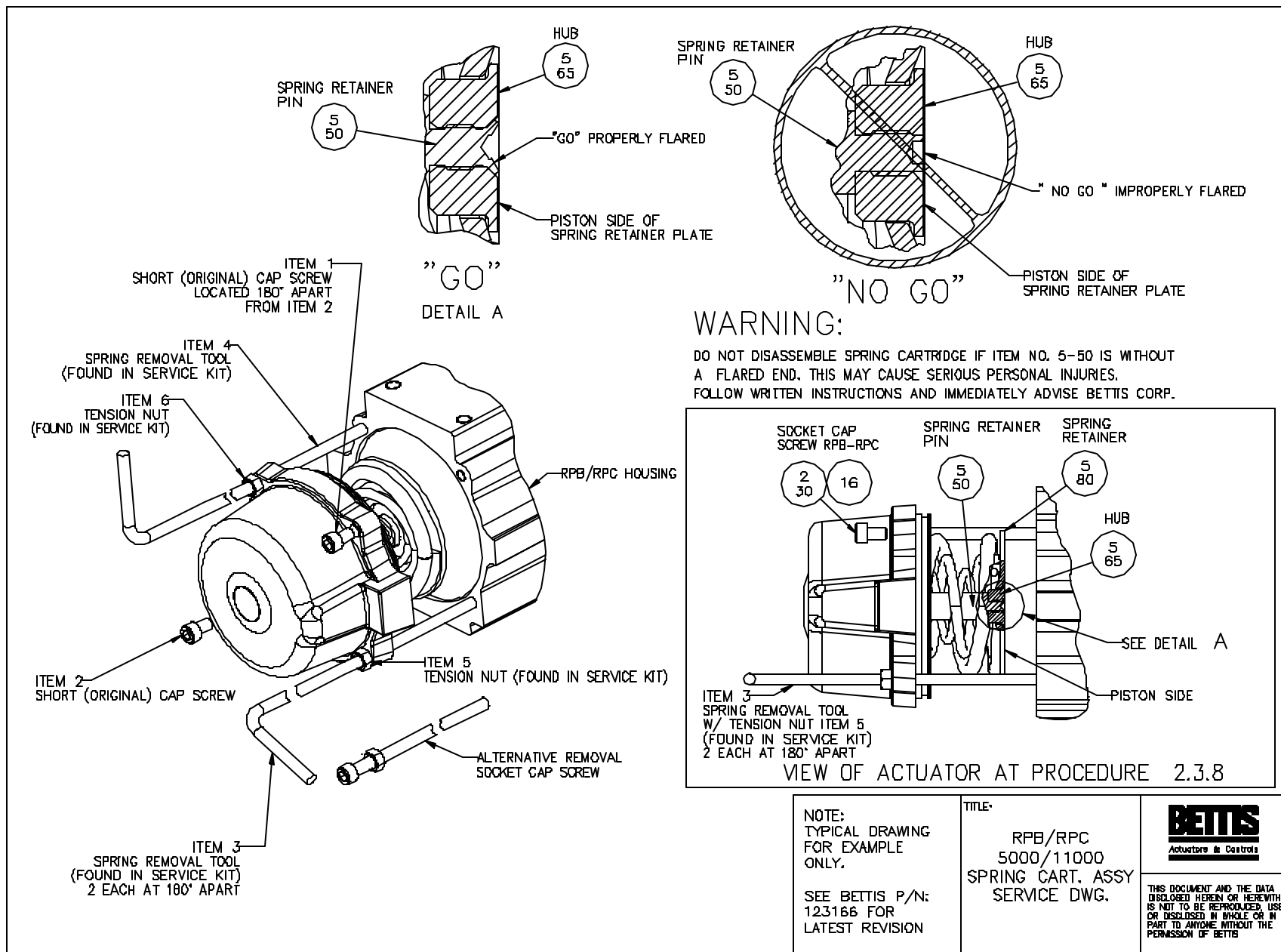

NOTE:  
 TYPICAL DRAWING  
 FOR EXAMPLE  
 ONLY.

SEE BETTIS P/N:  
 123166 FOR  
 LATEST REVISION

TITLE:  
 RPB/RPC  
 5000/11000  
 SPRING CART. ASSY  
 SERVICE DWG.



THIS DOCUMENT AND THE DATA  
 DISCLOSED HEREIN OR HEREWITH  
 IS NOT TO BE REPRODUCED, USED  
 OR DISCLOSED IN WHOLE OR IN  
 PART TO ANYONE WITHOUT THE  
 PERMISSION OF BETTIS