

REV	DATE	BY
1	06/02/08	40036

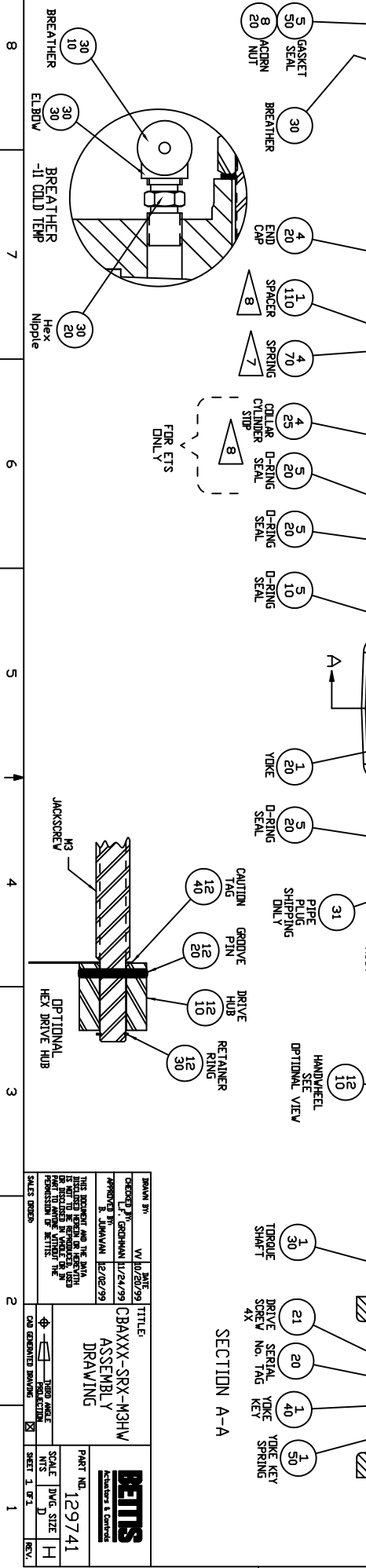
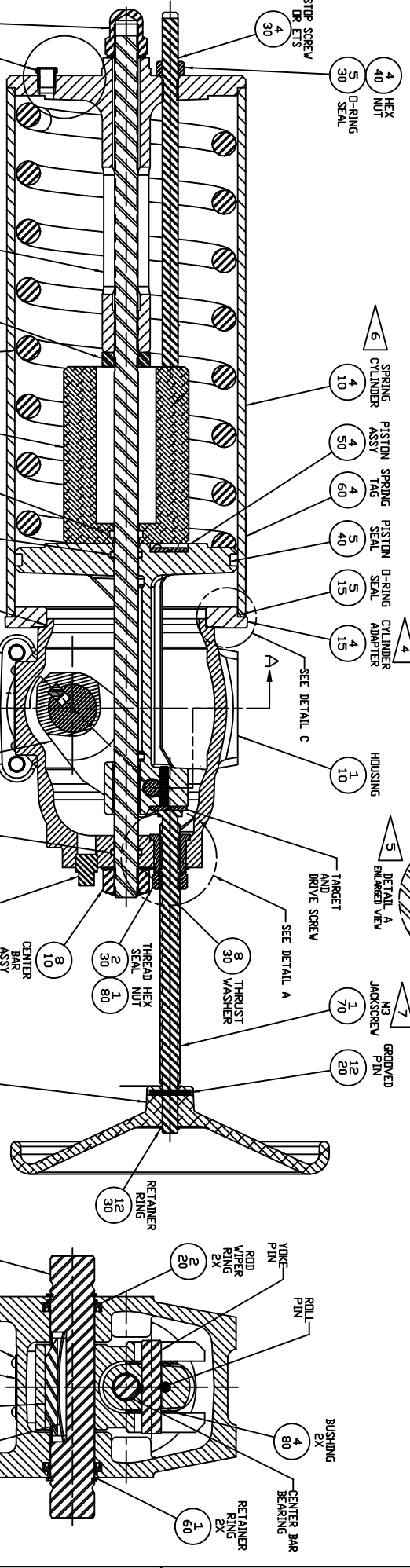
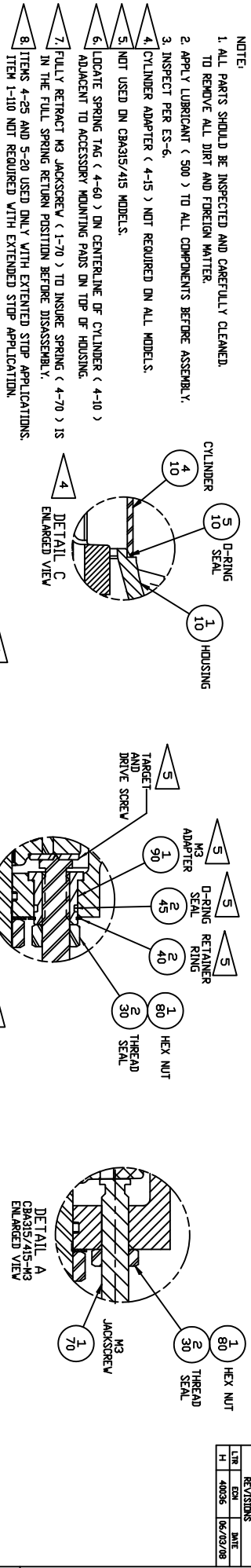

REV	DATE	BY	APP	CHK	DATE	BY	APP	CHK
1	06/02/08	40036			06/02/08	40036		

REVISIONS

DATE: 06/02/08

BY: 40036

REV: 1

SCALE: 1:1

DWG. SIZE: H

PART NO: 129741

TITLE: CB3035-SRX-M3HW ASSEMBLY DRAWING

APPROVED BY: R. JIMAVAN

DATE: 12/02/99

DESIGNED BY: J. GORDMAN

DATE: 12/24/99

DRAWN BY: VJ

DATE: 10/20/99

THIS DOCUMENT AND THE DATA CONTAINED HEREIN ARE UNCLASSIFIED EXCEPT WHERE SHOWN OTHERWISE IN THE FOOTNOTES OR WHERE INDICATED BY A CONTROLLED BY DATE

UNCLASSIFIED DATE: 08/02/00

CLASSIFICATION: UNCLASSIFIED

CONTROLLED BY: DATE: 08/02/00

CONTROLLED BY: DATE: 08/02/00

CONTROLLED BY: DATE: 08/02/00

CONTROLLED BY: DATE: 08/02/00