

**BETTIS®**

# WellGuard™ PWG Pneumatic Piston Actuator

Actuation for  
API 6A and 6D  
through conduit  
gate valves.

For shut down  
(reverse acting)  
or blow down  
(direct acting)  
applications.



  
**EMERSON™**  
Process Management

**EMERSON. CONSIDER IT SOLVED.™**

## The Company

Bettis has been providing quality valve actuation and control for more than 40 years, establishing itself as a pioneer and innovator in this industry, with products specifically engineered to your application. Today, as part of Emerson Process Management, we are the world's leading independent manufacturer of pneumatic and hydraulic valve actuators. Bettis products are used in almost every facet of the energy industry – oil and gas production, pipeline and processing. Our facility near Houston, Texas has more than 145,000 square feet of manufacturing capacity. We also operate modern manufacturing facilities in Edmonton, Canada and Mansfield, Ohio. We have been awarded the ISO 9001 designation indicating full compliance with worldwide standards for quality and documentation.

## General Description

The WellGuard™ PWG Piston range of pneumatic Control Fluid Powered linear actuators from Bettis Canada Ltd. is designed to be used in conjunction with Bettis valve bonnets to provide open and close control for major brands of API 6A through conduit reverse acting gate valves fitted to oil and gas wellhead Christmas trees and production flow lines. These actuators can also be used with API 6D and ANSI B16.34 valves where the bonnets are built to the Bettis design.

Suitable for onshore and offshore locations and ideal for use in H<sub>2</sub>S and CO<sub>2</sub> applications, the Bettis PWG range of piston actuators provides a simple and reliable valve automation solution. These actuators will be available in 10" and 14" diameters, suitable for valve sizes 1-13/16" thru 4-1/16" (18" model currently under development).

## Operating Principle

Valve actuation is achieved by applying a low pressure (maximum 250 psig) pneumatic control pressure to a piston in a closed housing thereby exerting a force which compresses a spring and extends a valve stem. This action is designed to open a reverse acting gate valve (or close a directing acting gate valve).

The valve is returned to its fail position upon venting the piston pressure. The actuator ensures that a fail position is achieved through the use of valve body pressure acting on the valve stem diameter assisted by coiled springs. The springs provide rapid and reliable valve shutdown when there is little or no valve body or flow-line pressure available.

The Bettis PWG actuator can be supplied to API 6A SDV, SSV and BDV to meet the quality assurance and test requirements of API 6A and Q1. The standard actuator can be supplied to meet the NACE MR0175-2000 requirements (optional).

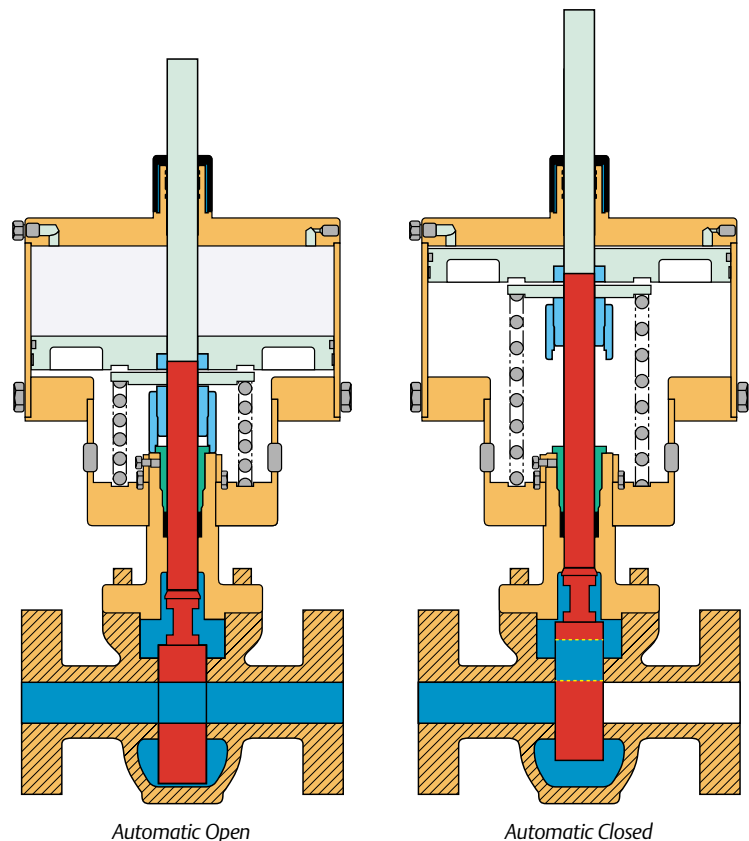

## Features and Benefits

The simple and reliable design of the PWG provides a range of features when actuated pneumatically:

- **Sour Service** – Compatible with both sweet and sour (NACE MR0175-2000) control fluids.
- **Visual Indication** – The shaft of the actuator extends through the top of the housing, with dual stem seals to provide local visual indication of valve position.
- **Maintenance** – The simple and reliable design allows quick and simple maintenance without the need of any specialized tools.
- **Reliability** – Springs provide reliable and quick shutdown assistance when flowline pressure is low or not available.
- **Compliance** – Certified for API 6A PR-1 and PR-2 applications. Valve/actuator packages can be supplied for PSL-1 to 3 applications.

- **Protection** – Integral, tamper resistant relief valve protects actuator from over-pressurization.
- **Operation** – Suitable for operation over a wide temperature range:  
**Actuator** -50°F (-46°C) to +150°F (+65°C)  
**Bonnet** -50°F (-46°C) to +250°F (+121°C)
- **Construction** – The actuator has no large mounting threads that could gall, corrode or be damaged.

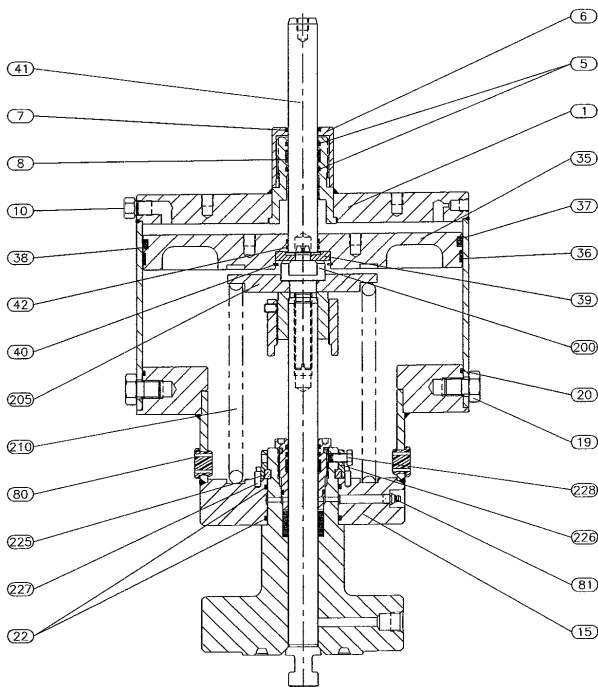

Notes: (Y) Recommended spare parts  
 (N) Not shown  
 Housing Capscrews (19) shown 15° from true orientation  
 Spiral Coil Pin (227) shown 90° from true orientation  
 Shown in closed position  
 Bonnet parts shown but not listed

ITEM	DESCRIPTION	MATERIAL	QTY	NOTE
1	CYLINDER	A350-LF2/A516-70/A333-6/Xylan	1	
5	O-RING, HUB	NITRILE	2	(Y)
6	THREAD PROTECTOR	DELIN	1	
7	WIPER, THD PROTECTOR	URETHANE	1	(Y)
8	GUIDE	DELIN	1	(Y)
10	OVERPRESSURE PROT DEV	SS/BRASS	1	
11	WARNING LABEL, RELIEF	VINYL	1	(N, Y)
15	LOWER HOUSING	A516-70/A333-6/Xylan	1	
19	BOLT MODIFICATION	SS 304	12	
20	O-RING, FLANGE	NITRILE	1	(Y)
22	O-RING, MOUNTING PLATE	NITRILE	2	(Y)
35	PISTON	A516-70/Xylan	1	
36	GUIDE, PISTON	HALLITE 506	1	
37	O-RING, PISTON	NITRILE	1	(Y)
38	BACK UP RING, PISTON	NITRILE	1	(Y)
39	THRUST COLLAR	17-4PH	1	
40	SPIRAL RETAINING RING	SS 302	1	
41	INDICATOR ROD	17-4PH	1	
42	O-RING, INDICATOR ROD	NITRILE	2	(Y)
80	GROMMET, VENT	EPDM	2	(Y)
81	VENT/LUBE FITTING	SS 304/././316	1	
85	NAMEPLATE	SS 304	1	(N)
86	NAMEPLATE DRIVE SCREW	SS 301/././304	2	(N)
200	SPRING BOLT	SS 410	1	
205	SPRING PLATE	A516-70/Xylan	1	
210	SPRING	5160/Xylan	1	
225	SPLIT RING, RETAINER	17-4PH	1	
226	RETAINER, SPLIT RING	17-4PH	1	
227	COIL SPRING PIN, RETAINER	SS 302	2	
228	BOLT, RETAINER	HXHC SS 304	1	
235	WARNING LABEL, SPRING	VINYL	1	(N, Y)

## Thrust Characteristics

ACTUATOR MODEL	MAXIMUM STROKE (INCHES)	DIAMETER (INCHES)	EFFECTIVE PISTON AREA (INCHES SQ.)	INITIAL NET THRUST OUTPUT (LB)	INITIAL NET THRUST OUTPUT @ MAWP (LB)
P1 x 10 x 3 x 3PWG	3.8	10	80	80P-600 (1)	19,400
P1 x 10 x 5 x 4PWG	5.0	10	80	80P-600 (1)	19,400
P1 x 14 x 3 x 3PWG	3.8	14	140	140P-600 (1)	34,400
P1 x 14 x 5 x 4PWG	5.0	14	140	140P-600 (1)	34,400
P1 x 18 x 3 x 3PWG	*	*	*	*	*
P1 x 18 x 5 x 4PWG	*	*	*	*	*

\*18" model currently under development  
 (1) P= Actuator control pressure – 250 psi

## Weights

ACTUATOR MODEL	WEIGHT (LBS)	WEIGHT (KG)
P1 x 10 x X x XPWG	165	75
P1 x 14 x X x XPWG	230	105
P1 x 18 x X x XPWG	*	*

\*18" model currently under development

## Dimensions

ACTUATOR MODEL	MAXIMUM STROKE	DIMENSION					WEIGHT (LB)
		A	B	C	D	E	
P1 x 10 x 3 x 3PWG	3.88	11.7	21.4	4.6	9.3	9.8	165
P1 x 10 x 5 x 4PWG	5.00	11.7	22.4	5.6	10.4	9.8	165
P1 x 14 x 3 x 3PWG	3.88	15.0	21.4	4.6	9.3	9.8	230
P1 x 14 x 5 x 4PWG	5.00	15.0	22.4	5.6	10.4	9.8	230
P1 x 18 x 3 x 3PWG	*	*	*	*	*	*	*
P1 x 18 x 5 x 4PWG	*	*	*	*	*	*	*

\*18" model currently under development

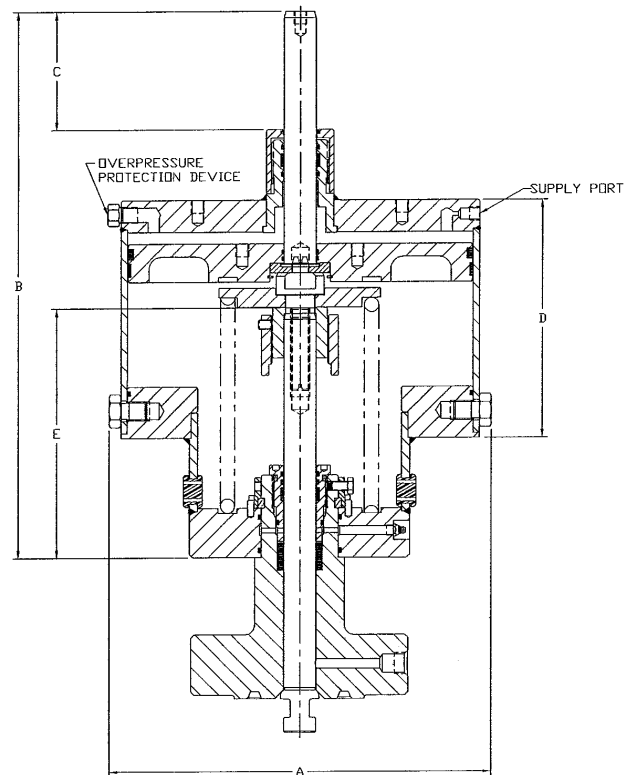

## Specifications

	STANDARD SERVICE	OPTIONAL FEATURES
<b>Operating Temp. Range</b>	-20° TO +150°F (-29° TO +65°C)	-50° TO +150°F (-46° TO +65°C)
<b>API 6A Monogramable</b>	Control Fluid Powered, PR 1 or PR 2	NACE, SSV

## Valve Bonnet Specifications

VALVE BONNET ASSEMBLY				
Operating Temp. Range	-50° TO +250°F	-46° TO +121°C		
Bonnet Size and Pressure Rating	Bonnet Weight (lb.)	Bonnet Weight (kg.)	Temp. Class	API Trim Class
1-13/16, 10,000	70	32	L thru V	AA, BB, CC, DD, EE, FF
1-13/16, 15,000	TBA	TBA	L thru V	AA, BB, CC, DD, EE, FF
2-1/16, 2,000 – 5,000	50	23	L thru V	AA, BB, CC, DD, EE, FF
2-1/16, 10,000	70	32	L thru V	AA, BB, CC, DD, EE, FF
2-1/16, 15,000	TBA	TBA	L thru V	AA, BB, CC, DD, EE, FF
2-9/16, 2,000 – 5,000	50	23	L thru V	AA, BB, CC, DD, EE, FF
2-9/16, 10,000	65	30	L thru V	AA, BB, CC, DD, EE, FF
2-9/16, 15,000	TBA	TBA	L thru V	AA, BB, CC, DD, EE, FF
3-1/8, 2,000 – 5,000	55	25	L thru V	AA, BB, CC, DD, EE, FF
3-1/16, 10,000	100	45	L thru V	AA, BB, CC, DD, EE, FF
3-1/16, 15,000	TBA	TBA	L thru V	AA, BB, CC, DD, EE, FF
4-1/16, 2,000 – 5,000	65	30	L thru V	AA, BB, CC, DD, EE, FF
4-1/16, 10,000	115	52	L thru V	AA, BB, CC, DD, EE, FF
4-1/16, 15,000	TBA	TBA	L thru V	AA, BB, CC, DD, EE, FF
<b>Bonnet in Conformance with API 6A</b>		<b>PSL 1, 2, or 3</b>	<b>SSV</b>	<b>PR 1 or 2</b>

## Service Conditions Reference Guide

MATERIAL CLASS	CLASSIFICATION, APPLICATION
AA	General Service, non-corrosive
BB	General Service, slightly corrosive
CC	General Service, moderate to high corrosive
DD	Sour Service, non-corrosive
EE	Sour Service, slightly corrosive
FF	Sour Service, moderate to high corrosive
HH	Very corrosive

TEMP. CLASS	MINIMUM AMBIENT TEMP.	MAXIMUM PROCESS TEMP.
K	-75°F (-60°C)	+180°F (+82°C)
L	-50°F (-46°C)	+180°F (+82°C)
P	-20°F (-29°C)	+180°F (+82°C)
R	+70°F (+21°C)	+70°F (+21°C)
S	0°F (-18°C)	+150°F (+66°C)
T	0°F (-18°C)	+180°F (+82°C)
U	0°F (-18°C)	+250°F (+121°C)
V	+35°F (+2°C)	+250°F (+121°C)
X	0°F (-18°C)	+350°F (+177°C)

## API Certification Number 6A-0397

Bettis Canada is authorized to use the official API monogram on Actuators and Bonnets for Surface Safety Valves manufactured and assembled under API Specification 6A for Valve and Wellhead equipment.

ISO 9001



Cert. Num. 93-13  
**Bettis Canada Ltd.**  
Edmonton, Alberta



API 6A Specification



[www.EmersonProcess.com/Bettis](http://www.EmersonProcess.com/Bettis)

**Bettis USA**  
P.O. Box 508  
Waller, TX 77484 U.S.A.  
T 281-727-5300  
F 281-727-5303  
**Info.Bettis@EmersonProcess.com**

**Bettis UK Ltd.**  
3 Furze Court  
114 Wickham Rd.  
Fareham, Hampshire PO 16 7SH  
T 44-1329-848-900  
F 44-1329-848-901  
**Info.Bettis-UK@EmersonProcess.com**

**Bettis Canada Ltd.**  
4112-91 A Street  
Edmonton, Alberta T6E 5V2  
Canada  
T 780-450-3600  
F 780-450-1400  
**Info.Bettis-Canada@EmersonProcess.com**

**Bettis France**  
30/36 Allee du Plateau  
93250 Villemomble  
France  
T 331-48-122610  
F 331-48-122619  
**Info.Bettis-France@EmersonProcess.com**

**Bettis Int'l Sales Office:**  
Calgary, Canada  
Rheinberg, Germany  
New Bombay, India  
Singapore



© 2002, Emerson Process Management. All rights reserved.

The Emerson logo is a trade mark and service mark of Emerson Electric Co.

The contents of this publication are presented for information purposes only, and while effort has been made to ensure their accuracy, they are not to be construed as warranties or guarantees, expressed or implied, regarding the products or services described herein or their use or applicability. All sales are governed by our terms and conditions, which are available on request. We reserve the right to modify or improve the designs or specifications of our products at any time without notice.

**BETTIS**

  
**EMERSON**  
Process Management